

# Tubular Anodes with Hidden Catalyst Concept and its Hydrogen Transport

Luis Bambace<sup>1</sup>, Fernando Ramos<sup>1</sup>, Hécio Villanova<sup>1</sup>, Alfredo Castro<sup>2</sup>, Renata Favalli<sup>2</sup>

<sup>1</sup> National Institute for Space research INPE, São José dos Campos, BR, Tel: 55-12-3945-6154, Fax: 55-12-3945-6163, Email: [bambace@dem.inpe.br](mailto:bambace@dem.inpe.br)

<sup>2</sup> Nuclear and Energetics Research Institute IPEN, São Paulo, BR Tel: 55-11-3133-9452, Fax: 55-12-3945-6163, Email: [ajcastro@ipen.br](mailto:ajcastro@ipen.br)

## 1 Introduction

This paper discusses the operation of patent pending fuel cell anodes made with microfiber fabrics as templates for tubular structures of porous walls with less than 1  $\mu\text{m}$  compact outer layer, and external diameter under 20  $\mu\text{m}$ . These anodes are able to operate with Hydrogen of relatively high CO content. Metal nm texture foam walls or entangled carbon nanotubes (nm-tubes) walls are filled with ionomer. A 18 nm thickness low porosity nickel shell over tubes was made, due to a proper activation with very close nm catalyst particles and, chlorides accelerators impregnation of the ionomer. Accelerator use assures a growing rate parallel to ionomer surface higher than other direction. Niobium or Vanadium shells may be pulsed electroplated temperatures in the 29-110 °C range with non aqueous ionic liquids. Palladium deposition, is also possible. As the accelerators research to Palladium and ionic liquids electroplating is not developed, minimum low porosity shell thickness is higher, but still bellow 1.5 times the foam cell size thanks to the distribution of catalyst grains.

## 2 Material and Methods

Using either polymer, copper or alumina  $\mu\text{m}$ -fiber fabrics as removable templates, and either pulsed electroplating or chemical vapor deposition techniques, porous wall tubes of internal and external diameters in the ranges of 6-12  $\mu\text{m}$  and 10-16  $\mu\text{m}$ , respectively, were made. The structures were filled with ionomer, catalyst and finally received a hydrogen (H) permeable shell layer. Some material are known to have low electrical resistance and good hydrogen transport properties, such as solubility and diffusion. Particularly the permeability, the product of solubility by the diffusion coefficient is the crucial property to the determination of H transport through a shell. Niobium (Nb), Vanadium (V) and Tantalum (Ta) have not only the highest hydrogen permeability, but also permeabilities that increase the colder is the environment. Palladium (Pd) permeability is just after these materials ones, but with values that increase with temperatures. Iron (Fe) and nickel (Ni) come next, with similar behaviors. Exact values of permeability of these last two metal depends on the type crystal structure and also of grain size, as interstitial

transport is much higher than by the grain body one. Metals H content in general are proportional to the square root of pressure, some polymers H content is proportional to pressure. Carbon is not amongst the best H<sub>2</sub> permeable material, but as carbon nm-tubes have very thin walls, and as they are hollow their H<sub>2</sub> transport were evaluated. The main sources of permeability data are references [1] to [8]. The most important data for 1 atm H<sub>2</sub> pressure and operation between 60 and 120°C are in table 1 and 2.

To calculate the H and CO fluxes it is necessary to use some “flux resistances” in analogy with thermal or real electric resistances. The first one is the H transport resistance by diffusion in the shell,  $R_{SH}$ , associated with inner,  $R_{OH}$ , and outer,  $R_{IH}$ , interface resistances, related to release and capture of H<sub>2</sub> by the surfaces. Due to the low dependence of thermal contact resistance with thickness, a constriction resistance  $R_{CONST-H}$ , equal to half of the contact resistance of Cooper [9] model, describes additional difficulties to H flux toward catalyst grains. It is assumed that H<sub>2</sub> adsorbed at a cylindrical surface, goes to a spherical particle, with half of it in the ionomer and half of it in the metal wall, and a internal catalyst particle resistance  $R_{CH}$  is put in series with the two. There are pores in the shell, as due to random catalyst particles positions and random aspects of structure and its small size neither an integer number of atoms fits in the space, nor it is possible to overcome differences by structural deformation in all cases. The number of pores is bigger than the number of activating particles, and there are some very small pores directly on the particles, as the inter-atomic distances of different materials does not match. So many pores in parallel that carries either H<sub>2</sub> or CO to the ionomer, with resistances  $R_{PECO}$  and  $R_{PEH}$ , and resistances related to access of gases trough pores to the catalyst particles,  $R_{PCCO}$  and  $R_{PCH}$ , which are linked to the single to multiple spots coplanar coupling in semi-infinite media. An internal resistances of particle to gases coming from these pores to the catalyst-ionomer interfaces  $R_{ICH}$  and  $R_{ICCO}$ . A Cooper constriction resistance  $R_{CONST-O}$  shall be added to O<sub>2</sub>. Resistances  $R_{PIX}$  are far bigger than diffusion ones in gas or liquid filled pores cases with diameters smaller than 1 nm. In gas filled case, the Knudsen number based in diameters are very big, and they behave alike a vacuum system pipe,

with a conductance equal the surface diffusion one in parallel with another obtained with the sum of probabilities of a molecule to pass directly, plus the ones of passing hitting the wall with a given specular and diffuse reflections chances, translated by the accommodation coefficient. If filled of liquid the pores will have a boundary layer of adsorbed molecules and organized molecules attracted by their dipoles that blocks the flux of CO and H<sub>2</sub>, so pore effective diameter, d<sub>PE</sub> is reduced by twice this layer thickness.

$$R_{SH} = (2 \pi L p_{HS})^{-1} \ln(d_{SHE}/d_{SHI}) \quad (1)$$

$$R_{CONST-X} = 0.25 \pi^{-1} a^{-1} (1-a/b)^{3/2}/n \quad (2)$$

$$R_{X-IE} = f_1 (2 \pi L \tau_i p_{XI})^{-1} \ln(d_{SHI}/d_{TI}) \quad (3)$$

$$R_{PC-X} \sim [\sum 0,5^{0,5}(d_{PE}^{-1}+b)+d_{ij}^{-1}]/ p_{XI} \quad (4)$$

where p<sub>HS</sub> is the H permeability of the shell, p<sub>XI</sub> is the ionomer permeability to the gas X, τ<sub>i</sub> is its tortuosity due to presence of the tube porous wall, f<sub>1</sub> is the occupation factor of ionomer in the wall, the tube inner, inner shell and outer shell diameters are respectively d<sub>TI</sub>, d<sub>SHI</sub> and d<sub>SHE</sub>; a is ¼ of the average area of a catalyst particle, b is (4 S n<sup>-1</sup> π<sup>-1</sup>)<sup>1/2</sup>, for n the number of particles and S the area, d<sub>ij</sub> are distances from source i to pore j. R<sub>PC-X</sub> is always bigger than real ones if all d<sub>ij</sub>=0 Permeabilities are effective ones, due to the very small thickness of the system components, see [10].

Gases that reach the ionomer have a resistance related with its path toward inner electrolyte, R<sub>HIE</sub> and R<sub>COIE</sub> and R<sub>OIE</sub> to O<sub>2</sub> outward path. If the porous wall support material is a good H transport media, catalyst may be placed on it, and as its H transport is relevant the corresponding structure may be represented as a fin, with a length bigger than wall thickness to catch the effect of the tortuous path. In all cases some core to surface H<sub>2</sub> flux resistance is assumed. Due to an intrinsic porosity macromolecules have a bigger diffusion coefficient than a low permeability metal, and double fin model tested for the metal ionomer H<sub>2</sub> transfer and its end transfer to the electrolyte. So:

$$d^2C_i/dx^2 - b_{ii}C_i + b_{ij}C_j = 0 \quad (5)$$

Where C<sub>1</sub> and C<sub>2</sub> are base material and ionomer concentrations, b<sub>12</sub>=2h/(r<sub>f</sub>D<sub>1</sub>), in which h is the interface transfer coefficient r<sub>f</sub> the equivalent foam/nm-tube fin radius, D<sub>1</sub> the diffusion coefficient; b<sub>22</sub>=b<sub>21</sub>=2h/(r<sub>io</sub>D<sub>2</sub>), to D<sub>2</sub> the ionomer diffusion coefficient for r<sub>io</sub> the equivalent ionomer fin radius; b<sub>11</sub>=b<sub>12</sub>-2i<sub>o</sub>·10<sup>dec</sup>/(r<sub>f</sub>D<sub>1</sub>) to i<sub>o</sub> the exchange current, dec the number of decades of polarization. A bi-quadratic equation gives the exponential ratios. Boundary conditions are insulated tips at liquid and shell interfaces for metal/foam and ionomer fins, knew concentration at shell for both fins. By solving this with actual coupling b<sub>ij</sub> ones sees that the wall

support material and ionomer are in equilibrium in short distances from the shell, so a single material model with average properties and eventual reaction used. This gives either a logarithmic field or a I<sub>o</sub> Bessel function one, where the distance multiplied by [4f i<sub>o</sub>·10<sup>dec</sup>/(r<sub>f</sub>D<sub>1</sub>)]<sup>0,5</sup> is the argument, with f the support material volume fraction. Large argument approximations to I<sub>v</sub>, field / R<sub>X-IE</sub>, I<sub>v</sub>(x)=e<sup>x</sup>(2πx)<sup>-0,5</sup>{1-(4v<sup>2</sup>-1)/(8x)+(4v<sup>2</sup>-9)(4v<sup>2</sup>-1)/(8x)<sup>2</sup>}, is used in general. Due to the presence of internal liquid electrolyte and the small thickness of ionomer tubular layer, it will be assumed its pores are entirely filled with liquid electrolyte. The carbon nm-tubes typically have 16 nm, and 3 nm wall thickness, so mean free paths are respectively 10 and 6,6 nm to H<sub>2</sub> and CO. The Knudsen number is nearly one to H<sub>2</sub>/H and near 2/3 to CO, surface diffusion is enhanced by free H/H<sub>2</sub> that jumps directly to distant points, and vacuum pipe calculation are valid. The resistances are combined according to the circuit shown in figure 1. The CO may be oxidized in the catalyst either reacting with water or with O<sub>2</sub>, H<sub>2</sub>O<sub>2</sub> or O<sub>2</sub>H<sup>+</sup>. The Pt catalyst H<sub>2</sub> and CO adsorption kinetic constants are 3.26·10<sup>-5</sup> and, 3.26·10<sup>-5</sup> m/s, desorption constants for H and CO are 3.81·10<sup>-6</sup> and 2.74·10<sup>-11</sup> mol m<sup>-1</sup>s<sup>-1</sup>, H and CO-OH<sub>ADS</sub> exchange currents respectively 8 A/m<sup>2</sup> and 1.04·10<sup>-6</sup> A/m<sup>2</sup>. CO-O<sub>2</sub> exchange current is near 2.5 times CO-OH<sub>ADS</sub> one, and H<sub>2</sub>O<sub>2</sub>-CO even higher. Sieverts ideal solid or Rault models solution kinetics are fast enough to equilibrium concentrations only to be considered. If excess ionomer is used, a internal pure layer of it brings an additional logarithmic resistance R<sub>OLX</sub>.

Figure 1: Resistances in the Transport Model.

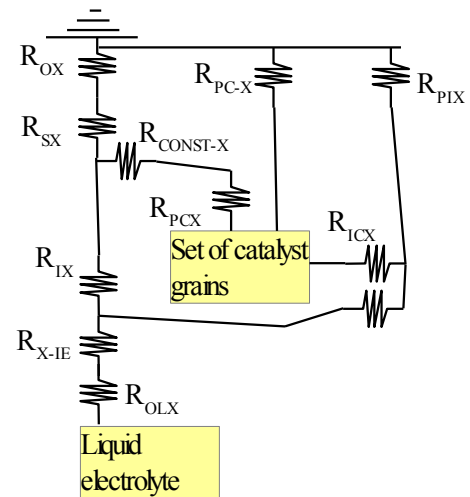

With this, the tolerance of the new architecture to high levels of CO in the fuel is evaluated as well as the cross flow of gases. Interface area for a given electrode thickness t<sub>e</sub> and mean area diameter d<sub>t</sub>, and tube fraction f<sub>t</sub> in the electrode is 4f<sub>t</sub>(t<sub>e</sub>/d<sub>t</sub>). But as the closer a point is from electric insulator it has more

reactivity, an efficiency factor  $\alpha$  shall be used and effective area is  $4\alpha f_i(t_e/d_i)$ . For common PEM cells, there are only small differences in CO and H transfer coefficient to the catalyst, due mainly to different permeability of them in the liquid present in the electrode. As the ratio between the transfer coefficients of H and CO becomes bigger, the cell is less sensitive to CO. Another point in CO tolerance is its consumption, linked to water gas shift in anode, electrochemical oxidation, O<sub>2</sub> bleeding and eventual H<sub>2</sub>O<sub>2</sub> presence. If the shell blocks O<sub>2</sub> its bleeding is safer, and despite of cathode consumption electrokinetic flows and small ionomer thickness allows some supply of O<sub>2</sub> to CO oxidation.

### 3 Results

The high hydrogen-cover shell interface area and the H transport at 80°C through the shell assures its high concentration at catalyst for Pd, V and Nb shells. Ni shell case is uncertain due to a large variation of literature permeability data, probably related with the higher grain interfacing values. Either in cubic or in hexagonal compact crystals, interstitial H<sub>2</sub>/H occurs, but the gaps are very close to H atomic diameter. Diffusion along grain boundaries seems to be the main mode, despite of vacancy, interstitialcy and crowd-ion mechanisms. CO nickel transport papers confirm that hypothesis. Due to the dense nucleation of the catalyst grains, and auto-catalytic processes employed the system grain size,  $g_s$ , is from 1.6 to 3 nm, much smaller than any literature measured Ni sample as in [1], and the system operates at higher temperature. Using these results with typical Arrhenius temperature and grain size corrections, a permeability of  $3.9 \cdot 10^{-10}$  is found. As the available grain contour perimeter per unit of area is proportional to  $1/g_s$ , permeabilities for our system are higher. Table 1 gives the equivalent partial H<sub>2</sub> pressure the catalyst grains should be exposed in gas environment to produce a flux of H<sub>2</sub> equivalent to the one assured by the set up at operational conditions, to catalyst loads of 0.1 mg-Pt/cm<sup>2</sup>-bp or 0.05 mg-Pd/cm<sup>2</sup>-bp, where the bp indicates that bipolar plate area is the reference. It was noticed that even to very small HER activity porous wall material, with an exchange current,  $i_f$ , of the order of 10<sup>-6</sup> A/m<sup>2</sup>, due to the large area and low electrode internal electrical resistance, almost no H<sub>2</sub> reaches internal electrolyte at 2 decades of chemical polarization for Ni foam setup despite the 2 to 3 μm ionomer thickness. This is easily shown with the ratio of  $I_1(mx)$  fluxes at the 2 shell positions, calculated with large argument approximations. For carbon nanotube with diffusive approximation and V foam  $i_f$  must raise to  $5 \cdot 10^{-4}$  A/m<sup>2</sup>, and is near  $8 \cdot 10^{-5}$  A/m<sup>2</sup> for effective transition regime Monte Carlo analysis. The H content in feed gas may be reduced if the power is

smaller. The shell pores are tiny in its inner, and eventually larger at outer layers if the shell is thick enough to defects propagation, or over 15 nm. Minimum low porosity shell thickness are about 16 nm to Ni (electroless), 60 nm to Pd, and 160 to ionic liquids electroplated V. As V is a very good H conductor its thickness was above minimum value. Thick shells of high H permeability material, blocks more effectively O<sub>2</sub> and CO, this made the natural O<sub>2</sub> bleeding to anode catalyst of the system, to be effectively blocked by the shell, so the feeding H<sub>2</sub> will not mix with O<sub>2</sub>. As O<sub>2</sub> access to catalyst is partially blocked by the ionomer and even by liquid electrolyte, despite of its convective flow, levels are not harmful to catalysis, even CO content in feeding mixture is low, and its bleeding high enough to a fast oxidation of residual CO from dirty mixtures. In the case of 0.35 mm thick anodes, the Ni shell couplings for H<sub>2</sub>, CO and O<sub>2</sub> are 0.328, 2.72E-2 and 4.09E-4 mol/m<sup>2</sup>-bp/s/atm<sup>0.5</sup>. This means a strong selectivity in favor to H<sub>2</sub>. Palladium shell has an H<sub>2</sub> coupling of 6.9100 mol/m<sup>2</sup>-bp/s/atm<sup>0.5</sup>. Being thicker CO and O<sub>2</sub> couplings falls to 9E-3 and 1.4E-4 mol/m<sup>2</sup>-bp/s/atm<sup>0.5</sup>. The V shell couplings are 1.88E+8, 3.3E-3 and 4.9E-5 mol/m<sup>2</sup>-bp/s/atm<sup>0.5</sup> for H<sub>2</sub>, CO and O<sub>2</sub> respectively. This means that CO and O<sub>2</sub> transfer to H<sub>2</sub> feeding cavity is effectively blocked by the shell. Once the cell is off, H<sub>2</sub> blocking due to reaction ceases and filled Ni foam coupling becomes 0.16 mol/m<sup>2</sup>-bp/s/atm<sup>0.5</sup> only, critical for high permeability shells, being it necessary to cut H<sub>2</sub> feeding as soon as possible. Corresponding couplings to carbon nm-tubes and vanadium foam are even higher. CO and O<sub>2</sub> couplings are in the 8E-5 to 1.2 E-4 mol/m<sup>2</sup>-bp/s/atm<sup>0.5</sup> range. At operation the cell has an electrokinetic convention and levels of O<sub>2</sub> about 0.04 mol/m<sup>3</sup> at liquid electrolyte so some residual O<sub>2</sub> will be available to help CO oxidation, and this kinetic is known to be better than adsorbed OH one.

Table 1: H<sub>2</sub> equivalent contents at catalyst for different shell materials  $H_{2FLUX} = K(P_E^{0.5} - P_C^{0.5})$

Shell material & thickness (nm)	Current (A/m <sup>2</sup> )	Sieverts H <sub>2</sub> Pressure loss (Pa)	Electrode thickness (mm)
Ni / 18	18500	50,000	0.35
Ni / 18	50000	95000	0.35
Pd / 48	5000	0.2	0.35
Pd / 48	9000	0.4	0.35
V / 300	9000	5E-4	0.35

The average chemical polarization needed to produce the above currents, is very low, once the catalyst is plenty of H<sub>2</sub>. In the 50000 A/m<sup>2</sup> Ni shell case, the concentration is equal pure water interface one to a pressure of 1.86 atm. Notice that more than half of the total catalysts grains area is operating in contact with

ionomer. Reported exchange currents for Pt in water with this equilibrium  $H_2$  content is  $8 A/m^2-Pt_{EXPOSED}$ . The current IPEN Pt or Pt-Ru grains diameter, produced by electron beam or radiation reduction in alcohol, is 1.5 nm, so for 50% of the grain inserted in the shell the catalysis area is  $93 m^2$ . This means less 1.7 decades of polarization to reach  $70000A/m^2-bp$ , or less as more than half of grain area is exposed to ionomer, notice that these grains are the seeds of auto-catalytic process. Depending of reaction mechanism 100 to 120 mV. For other shells polarization is much smaller. Ionomer resistance is only  $750 \mu\Omega cm/cm^2-bp$  for an anode with  $16 \mu m$  external diameter tubes and a interface area to bipolar area ratio of 20 filled with Nafion. Even considering current distribution related losses are of few mV. This is the main reason less conductive ionomer may be used. An electronic microscope image of one of the tested structures is shown in figure 2. A complete cell setup is in figure 3. This tube has  $10 \mu m$  of internal diameter, and it is not filled with ionomer to easy the image obtaining.

Figure 2: Complete cell setup

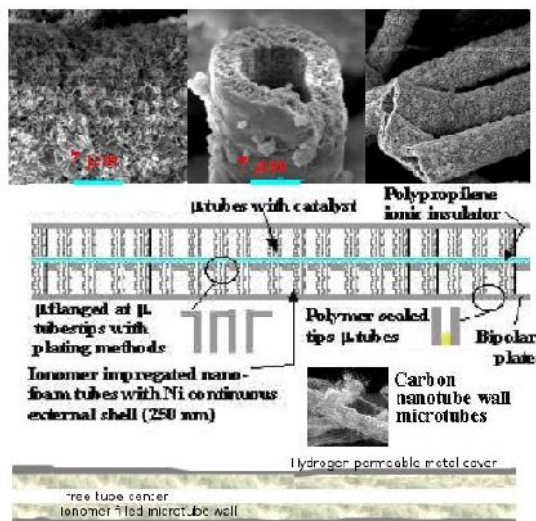
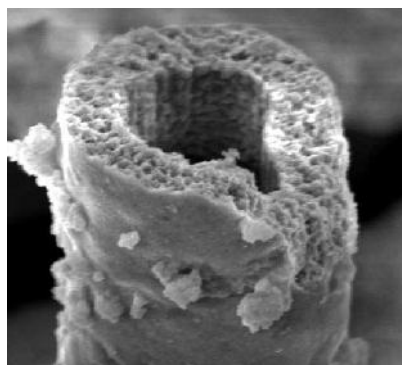

Figure 3. Typical  $5 \mu m$  radius of anode fabrics.



Ni foam has some catalytic activity, but as it is pro-

tected against corrosion in acid media with passivation layers of Ni-Cr-N, borides or oxides, with this protection it probably will not have any catalytic activity. This way a small cost low activity catalyst is employed to avoid  $H_2$  cross flow. The closer the catalyst is from outer wall, more  $H_2$  is available and more efficient its use, this way top catalyst will be placed out of the wall only in there is not enough space on wall inner surface. Possible control catalysts are either organometallic of Ru-sulfides HER catalysts not with the purpose of current production but to block  $H_2$  flow towards electrolyte, and mitigate excessive  $O_2$  transport. Arrangements with good  $H_2$  penetration, as vanadium foam, offers more catalyst support area, but they have more cross flow problems. This foam showed over 20 times more H transport capacity than carbon nanotubes, due to the strong wall iteration of the latter. This and other tested geometries are the result of new nanotechnology processes in fuel cell design.

#### 4 Conclusions

The study shows that tubular fabric anode systems with proper design are promising anodes for future high power fuels cells. Vanadium and Palladium shells are able to assure this easily Ni shells seems to be also feasible but must needs confirmation of property changes in the 3 nm grains size material. Small  $O_2$  cross over to the ionomer in the inner of  $\mu$ -tubes is also blocked by the tubes shells, being due to that less problematic to safety than in other arrangements. The residual levels of  $O_2$  are able to enhance CO oxidation, allowing the system to operate at even bigger levels of CO at fuel. With the cell  $H_2$  crossing is about  $0.16 mol/m^2-bp/s$ , implying in the need of immediate cut of its supply.

#### References

- [1] Doylei, D. M; Palumbo, G; Aust K. T; El-Sherik A. M; ERB U. *Acta metall, mater.* Vol. 43, No. 8, pp. 3027 3033, 1995.
- [2] Zajec,B; Nemanic,V. Determination of parameters in surface limited hydrogen permeation through metal membrane. *Journal of Membrane Science* 280 (2006) 335–342.
- [3] Akamatsua,T; Kumea,Y; Komiya, K; Yukawaa, H; Morinagaa, M; Yamaguchib, S. Electrochemical method for measuring hydrogen permeability through metals. *Journal of Alloys and Compounds* 393 (2005) 302–306.
- [4] Kazarinov, R.F. Thin-film, Solid-state Proton Exchange Membranes for Fuel Cells. *Bell Labs.* 2005.

- [5] Kocha,S.S; Yang, J.D; Yi, J.S. Characterization of Gas Crossover and Its Implications in PEM Fuel Cells. UTC Fuel Cells, South Windsor, CT 06074. DOI 10.1002/aic.10780. *Published online February 9, 2006 in Wiley InterScience*
- [6] Choi, P. Investigation of Thermodynamic and Transport Properties of Proton-Exchange Membranes in Fuel Cell Applications. *Worcester Polytechnic Institute. PhD Thesis. 2004.*
- [7] Sedano,L.A; Alberici, S; Perujo,A; Camposilvan, J; Douglas, K. Derivation of hydrogen transport parameters in carbon fibre composites by modelling transient release in isovolumetric desorption experiments. *Journal of Nuclear Materials* 258-263 (1998).
- [8] Edwards, A. G. Measurement of the diffusion rate of hydrogen in nickel. *British Journal of Applied Physics* 406 (8), 1957
- [9] Cooper, M. G., Mikic, B. B; Yovanovich, M. M., Thermal Contact Conductance. *Journal of Heat Mass Transfer*, 12, 279-300, 1969.
- [10] Bitter, J.G.A. Transport Mechanisms in Membrane Separation Processes. Plenum Publishing Corporation. NY.ISBN 0-306-43849-6