

TWO-PHASE FLOW ASSESSMENT AND VOID FRACTION MEASUREMENT OF A PILOT NATURAL CIRCULATION LOOP USING CAPACITANCE PROBE

Marcelo S. Rocha and Eduardo L. L. Cabral

Instituto de Pesquisas Energéticas e Nucleares, IPEN - CNEN/SP
Centro de Engenharia Nuclear - CEN
Av. Professor Lineu Prestes 2242
05508-000 São Paulo, SP
msrocha@ipen.br
elcabral@ipen.br

ABSTRACT

This article focuses the project, construction and tests of a capacitance probe for void fraction measurement and two-phase flow assessment in a natural circulation loop. Two-phase flow patterns and the associated variables are very important in natural circulation circuits and it is used in the new generation of nuclear reactors for residual heat removal during shut-off and emergency events. The capacitance probe was calibrated to measure the instantaneous bulk void fraction in a vertical tube section of a natural circulation loop. Instantaneous signals generated by the capacitance probe allow the determination of the local bulk void fraction. The probe design is presented and discussed and void fraction data obtained by the probe are compared with theoretical void fraction calculated by analytical models from literature.

1. INTRODUCTION

1.1. The Natural Circulation Cooling Prototype

A prototype of a natural circulation cooling circuit simulating in a small scale the real phenomenon of natural convection currents formed by a heat source and a heat sink in a closed pipeline circuit of a nuclear reactor was designed and constructed in the laboratory of the Nuclear Engineering Center (CEN) of IPEN to test and visualization of all involved phenomena.

The natural circulation cooling system has been important technique for nuclear reactors cooling design because your operational simplicity, safety, and maintenance reduction features [1, 2]. In order to achieve reliable cooling performances, the natural circulation must to be designed and operated to avoid some physical phenomena associated to the two-phase instabilities.

Those natural circulation cooling loops operate governed by the interplay of inertia, buoyancy and friction forces, being important to the residual heat removing in case of primary circuit fail. They became largely studied since the known accident of *Three Mile Island*.

Two-phase heat transfer process control, design, safety, and performance improvement require the knowledge of heat transfer coefficient and the void fraction. As can be proved by predicting methods the heat transfer coefficient is dependent on the void fraction distribution and flow regime. So far oscillatory heat transfer problem, the flow boiling, is affected by the influence of flow direction on the heat transfer coefficient and void fraction during fully developed nucleate boiling in the vertical channel.

Void fraction measurement have been performed by means of many techniques in heated tubes with subcooled liquids [1-4], results show that the direction of the flow affect the void fraction considerably.

The natural circulation refrigeration loop operational behavior in similar but reduced scale conditions as it should operate in a real nuclear reactor. In fact, the void fraction sensor is a key to determine two-phase flow variables (mainly void fraction), flow patterns behind other parameters with minimum uncertainty, once many other variables are directly associated with void fraction.

1.2. Two-Phase Flow Sensors

Void fraction measuring techniques have been extensively studied in last decades in connection with determining the void fraction and characterizing the two-phase flow structure and regime. Two-phase are characterized as a largely fluctuating, requiring the use a specific instrumentation. Instrumentation development is the important for the multiphase flow modeling as well as for flow monitoring purposes. Many techniques for void fraction measurement have been developed, and their particular success depends on a specific application. The signal response is two-phase flow structure-dependent and can be designed to indicate void fraction values that are instantaneous or time-averaged, local or global.

The electrical impedance technique is one of the most promised techniques for void fraction measurement, whose working principle relies on the difference in electrical impedance of each fluid phase. Invasive to the flow or non-invasive sensor configurations have been investigated for local void fraction distribution and the phase interfacial area determination, using, impedance method. The impedance probe method is the simplest and probably the cheapest of all techniques. Noninvasive probe arrangements have been conceived in a flush configuration mounted with the pipe wall, with advantage that they do not disturb the two-phase flow distribution.

Flush mounted impedance probes formed by a pair of electrodes are still been used along with flow data statistical processing for both vertical as well as horizontal gas-liquid flow [5–8]. This simple configuration is known to be accurate to indicate the average void fraction as long as the void fraction is cross-section uniformly distributed. However, non-uniform cross-section void fraction distribution changes the instantaneous signal, giving rise to erroneous indication of the actual average void fraction.

Two-phase mixture impedance technique can be basically divided in two other types: the resistive and the capacitive impedance technique. As a proposed solution, a single pair of electrodes sensor is required to eliminate the misreading due to that void fraction non-uniform distribution problem. Later, other studies were carried out in connection with the determination of instantaneous signal response to void fraction wave propagation.

Electrical impedance technique can also be applied to the liquid-liquid mixture for mass content determination [7-8]. The authors obtained a transference function of the mean electrical conductivity of different ethanol and gasoline blends at several temperatures.

Capacitive sensors are suitable for many applications and its success is associated to the electrodes geometry and flow direction. Literature presents many studies in which it is clear the dependency of the system characteristics, temperature, and the probe geometry and

measurement technique. So, the first step for an experimental study of impedance sensor for void fraction measurement is the choice of the best sensor type, geometry and measurement technique for the system characteristics.

Three main techniques for void fraction measurement are commonly used for sensors calibration: radioactive absorption and scattering, direct volume measurement by quick-closing valves or mean density variation technique.

Temperature influences strongly on fluid electrical capacitance. For water-steam flow, an increase in temperature from 25 °C to 50 °C doubles the conductivity, whereas the relative permittivity decreases by only 15%. Moreover, the relative permittivity of the water is not affected by a change of ionic concentration. Drift can be reduced by operating at sufficiently high frequency to give domination by capacitance.

The present type of sensor operates based on the dissimilarity of electrical properties of the liquid and vapor demineralized water. According to the operational frequency of the signal applied between the electrodes along with the knowledge of the electrical properties of the fluids, the average dominating impedance of the two-phase mixture filling in the cross-section may be either resistive, capacitive, or both. The sensor analyzed in this study operates in the capacitive range. The elementary electrical model of the sensor and the measuring system that operates without electrolysis near electrodes surfaces can be compared to a parallel RC circuit.

A parallel RC circuit analysis shows in a simple way that, for the resistive operating range, it is possible to associate the overall two-phase mixture resistance with the corresponding electrical average conductivity, as follows:

Fluid capacitance is strongly temperature-dependent. To get around this problem, a common technique is to work with a dimensionless capacitance rather than the absolute value so that the temperature influence is diminished, if not eliminated. Although the use of dimensionless capacitance use, another mathematical correction must be applied to the sensor signals guaranteeing the less temperature effect influence as possible. The dimensionless capacitance is the ratio between the actual two-phase water-steam capacitance at the same temperature. By taking regular water electrical properties (dielectric), one can estimate the operating frequency of the applied signal, which results in a range, for capacitive impedance measurement, $f \approx 1$ MHz.

2. EXPERMENTS AND METHODS

2.1. Natural Circulation Circuit

The natural circulation circuit composed by glass Pyrex tubes of 38 mm internal diameter, 2.6 m height, with an upward vertical pipe where a heat source section with a 4.5 kW electrical resistance is located, and a vertical downward pipe where a spiral heat exchanger removes part of the total heat. The capacitance sensor for void fraction measurement is located at the vertical upward pipe above the heating section as can be seen in Fig. 1.

The expansion tank absorbs the flow density and pressure variation, and it is connected to the inferior section point. The superior expansion tank nozzle keep opened to atmosphere

permitting the circuit run at atmosphere pressure. All the circuit is not thermally insulated permitting the visualization of all circuit sections.

The boiler section is an electrical resistance is controlled by a voltage controller that makes the power control from zero to about 4.5 kWe. Temperatures are measured in 16 points along the circuit, and T type thermocouples have been used. There are two points of surface temperature measurement and 14 points of internal flow temperature measurement. There are two points of pressure measurement made by piezoelectric transducers. All data are acquired by a 32 channels acquisition data system. Before, the secondary flow from heat exchanger is monitored by two points of temperature and flow measurement.

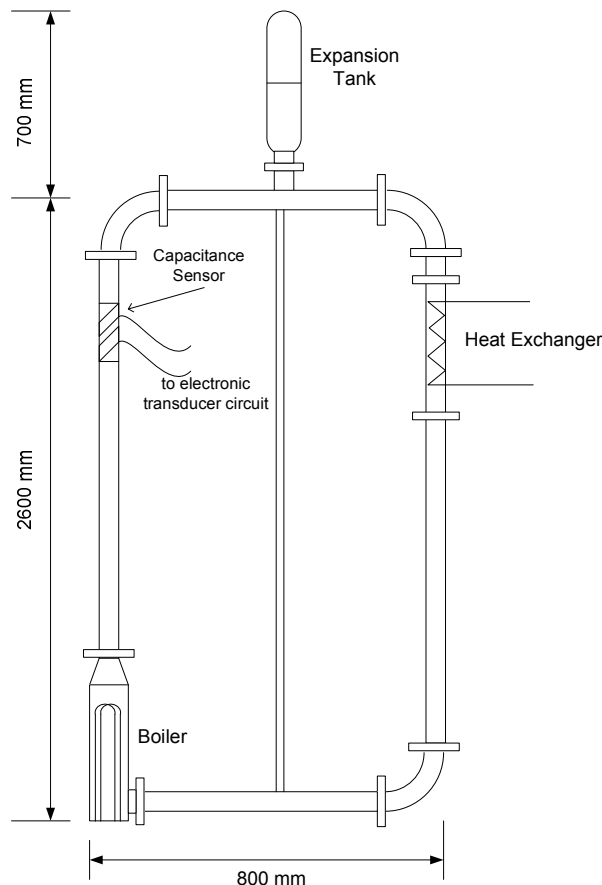

Figure 1. Schematics of the natural circulation.

2.2. Capacitance Sensor Calibration

A capacitance sensor was designed and tested for void fraction measurement, as can be seen in Fig. 2. A copper tape coating is wound around the tube which has an i.d. of 38 mm. Electrode 1 makes three complete revolutions around the tube, electrode 2 only two. The pitch of the helix is πD , hence the active length of the sensor is $2\pi D$ (~ 4 dia). The shield electrodes fix stray capacitance and make an analytical approach of the helical cross-capacitor possible. The guard electrodes are connected electrically to the two shield electrodes. Special dual cables with characteristic capacitance of about pico-Faradays (10^{-12} F) are used to connect the electronic circuit to the shield electrodes. This arrangement permits a capacitance measurement independently of the length of the coaxial leads and external fields.

For the natural circulation circuit where the capacitance sensor is mounted, the void fraction range varies from 0 to about 60%, as revealed by the simulation results from RELAP5 [2]. The actual volumetric void fraction will be measured by two different techniques, which is going to be considered the calibration standards within this project scope. Two techniques are going to be considered as the actual average volumetric void fraction measurement: the first one is the gravimetric method (GM), because the liquid at rest, resulting in a small pressure column oscillation, provide accurate measurements and furnishing small measurement uncertainties (less than 5% according to literature).

The second standard technique is based on the use of existing well posed prediction theoretical models for a vertical column two-phase flow.

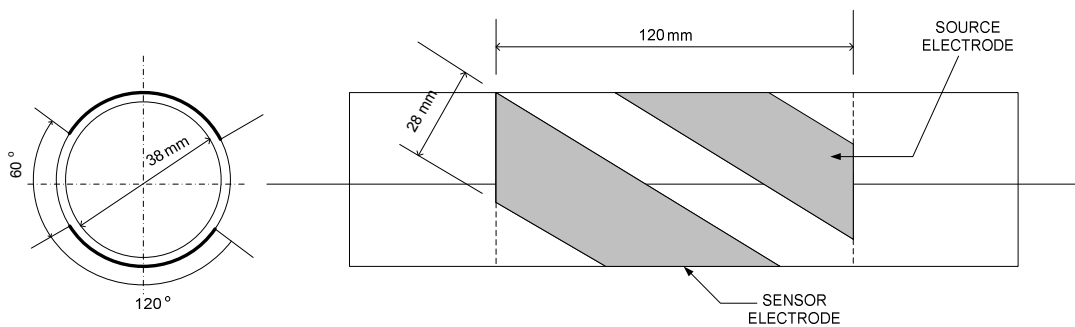

Figure 2. Capacitance sensor dimensions.

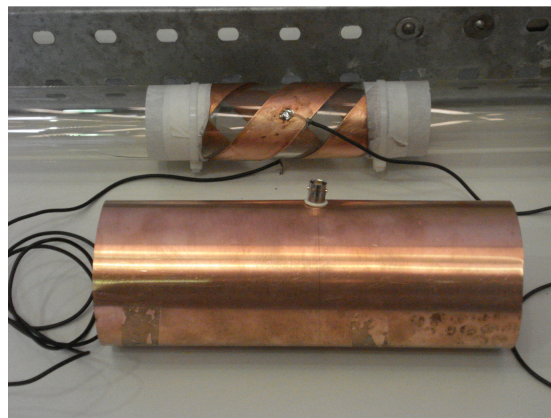
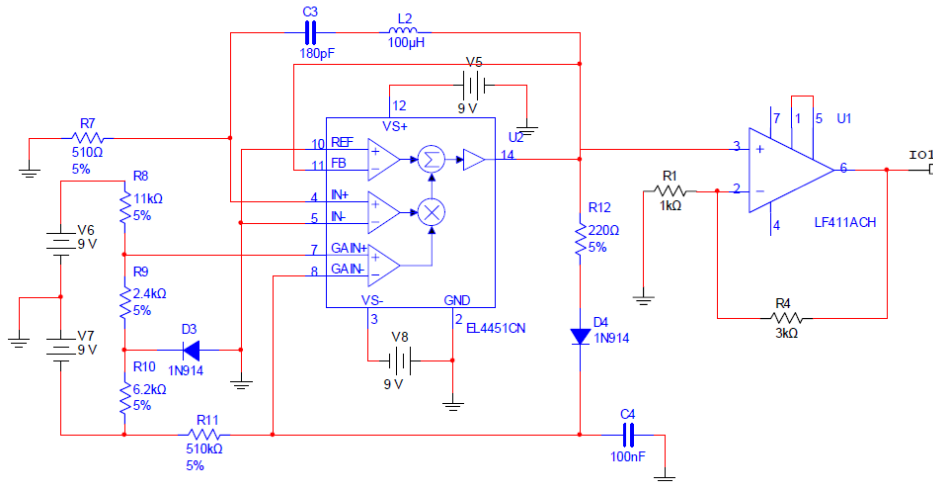

Figure 3. Capacitance sensor assembled with electromagnetic insulator.

2.3 Electronic Demodulation Circuit

An electronic circuit was designed and constructed to make the capacitance signal transduction to an outlet signal (V_0) varying from 0 to 5V DC, corresponding to the void fraction variation from 0 to 100%. Figure 4 shows the electronic circuit schematics.



(a)

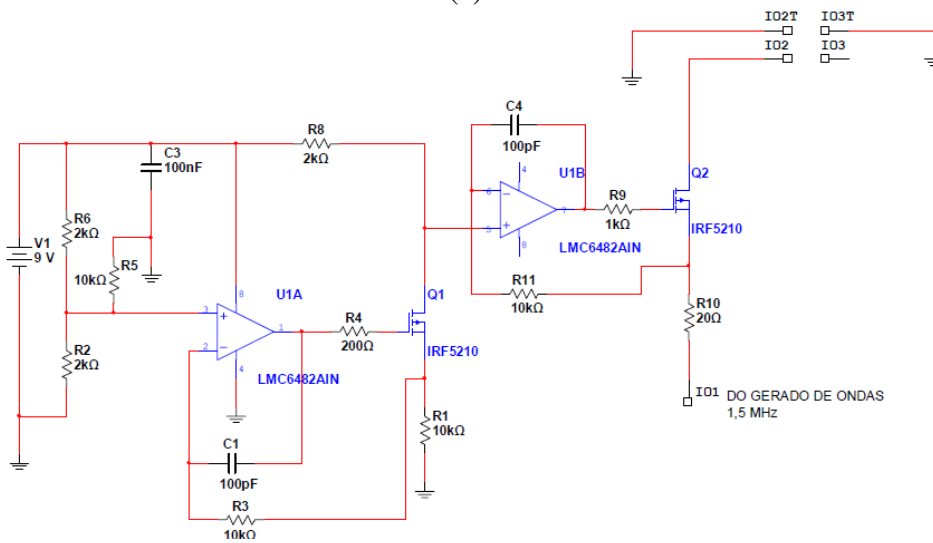

(b)

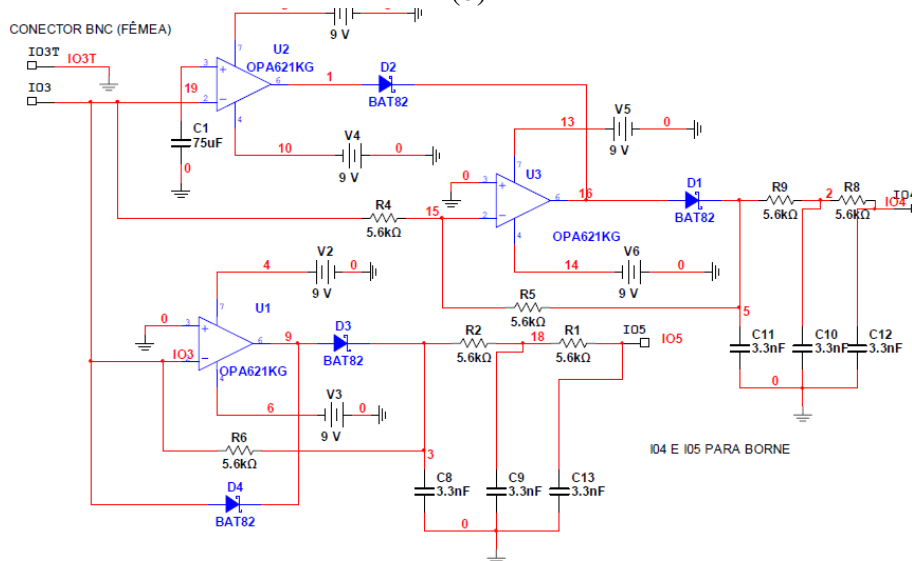

(c)

Figure 4. Electronic circuit diagram (a) wave generation circuit, (b) current generation circuit, and (c) signal demodulation circuit.

The electronic circuit consists on a signal generator which furnishes a sinusoidal wave, 3 Vpp/0.8 MHz signal that modules a current source producing a (V_S) 3 Vpp/0.7 MHz, 20mA signal that is applied to the dual helical electrodes capacitance sensor. The two-phase mixture capacitance (C_X) variation into the vertical tube produces a signal that is amplified, rectified and filtered to a 100 Hz signal (V_0) that, finally, is amplified and adjusted to be measured by a data acquisition system. The electronic circuit module is connected to the capacitance sensor by coaxial cables with low capacitance (C_{S1} and C_{S2}). The resistive impedance parcel (R_X) can be disregarded, once for high frequencies the resistance is too low to be accounted.

The electronic demodulation circuit is composed by three parts: the wave generation circuit, the current generation circuit, and the signal demodulation circuit.

The wave generation creates the wave signal with amplitude and frequency to be followed by a current generation circuit that generates the signal with amplitude, frequency and relatively high current to be applied to the electrodes (emission electrode). The receptor electrode receives the signal and so, it is demodulated and filtered in the demodulation circuit. The Fig. 4 shows the three electronic circuit schemes.

3. CAPACITANCE SENSOR MODEL

3.1 The Capacitance Sensor Electrical Model

Capacitance sensors have been modeled by many authors, and some analytical solutions were obtained for specific flow conditions. There are many works in which the capacitance sensor was modeled, and some analytical solutions were obtained for specific flow conditions. Geraets and Borst (1988) [4] show that, for a simplified electrode configuration compound of two concave flush mounted electrodes, the capacitance and electric field distribution can be calculated by Laplace equation in a cylindrical coordinates as follows:

$$\frac{\partial^2 V}{\partial r^2} + \frac{1}{r} \frac{\partial V}{\partial r} + \frac{1}{r^2} \frac{\partial^2 V}{\partial \phi^2} + \frac{\partial^2 V}{\partial z^2} = 0 \quad (1)$$

where, V is the potential distribution, r is the radial direction coordinate, z is the axial direction coordinate, and ϕ is the circumferential direction coordinate.

After a series of mathematical, geometric and boundary conditions applications, the final analytical solution for the eq. (1) is:

$$V(r, \xi) = \frac{\xi V_0}{\pi} + \frac{2V_0}{\pi} \sum_{n=1}^{\infty} \frac{\sin(n\xi) \cos(n\xi) I_n\left(\frac{nr}{pR}\right)}{n I_n\left(\frac{n}{p}\right)} \quad (2)$$

where, $\xi = \phi - z / pR$, R is a half of the inner diameter. The pitch parameter p is equal to the ratio of the pitch of the helix (s) and the circumference ($2\pi R$), $p = s / 2\pi R$. The parameter I_n is a modified Bessel function of the first order, and n is an integer. The internal cross-capacitance per unit length (C') can be written as:

$$C' = \frac{2\varepsilon_0\varepsilon_r}{\pi} \left\{ \ln \frac{\sin\left[\frac{(\phi_1 + \phi_2)}{2}\right]}{\sin\left[\frac{(\phi_2 - \phi_1)}{2}\right]} + \sum_{n=1}^{\infty} \frac{2 \sin(n\phi_1) \sin(n\phi_2) I_{n+1}\left(\frac{n}{p}\right)}{pn I_n\left(\frac{n}{p}\right)} \right\} \quad (3)$$

where, ε_0 , and ε_r are the free space permittivity and the relative permittivity of the internal mixture flow.

A dimensionless capacitance has been proposed [10] as a way to avoid some fluid properties influences on the calibration curve. It can be describe as follows:

$$C^* = \frac{C_x - C_G}{C_L - C_G} \quad (4)$$

where, C^* is the two-phase measured capacitance, C_G is the pure gas filled capacitance, and C_L is the pure liquid filled capacitance.

3.2. Temperature Effect on Sensor Signal

One of the main characteristics of the natural circulation refrigeration circuit is the flow temperature variation during all heat dynamic cycle observed. The electrical properties changing along the cycle must be evaluated, so the sensor's outlet signal will change too.

The two-phase mixture temperature variation is one of the critical parameter that influences the capacitance changing ($C_X = f(T)$). As a consequence the outlet signal (V_0) from electronic transducer circuit will varies as the flow temperature and void fraction varies too, $V_0 = f(\alpha, T)$, where α is the void fraction, and T is the two-phase flow mixture temperature.

A complete description on how temperature influences the outlet signal (V_0) can be seen in [9]. According to the authors, the outlet signal is influenced by flow temperature variation for a two helical electrodes as shown in section 2, by:

$$V_0 = V - a[1 - \alpha(T_0)][\varepsilon_L(T) - \varepsilon_L(T_0)] \quad (5)$$

where V_0 is the sensor outlet signal for a calibration temperature T_0 , V is the sensor outlet signal for a temperature T , α is the void fraction, a is the voltage derivative to the temperature dV/dT , and ε_L is the liquid relative permittivity. The calibration tests were carried out in a certain temperature $T_0 = 24$ °C, and the total heat cycle varies from 20 °C to 100 °C.

Accordingly, the liquid relative permittivity variation ($d\varepsilon_L/dT$) variation with temperature is many times higher than vapor relative permittivity variation ($d\varepsilon_V/dT$), so this is the motive that it is not regarded in this formulation.

4. RESULTS

Preliminary tests carried out consisted in the demineralized water capacitance measurement, and test show the outlet signal variation with the dielectric constant changing with temperature, as is shown in Table 1.

Table 1. Liquid capacitance variation with temperature.

<i>Test</i>	<i>Temperature (°C)</i>	<i>Capacitance measurement 1 (pF)</i>	<i>Capacitance measurement 2 (pF)</i>	<i>Average Capacitance (pF)</i>
1	25	23,4	23,7	23,55
2	30	23,5	23,7	23,6
3	35	23,6	23,8	23,7
4	40	23,6	23,9	23,75
5	45	23,7	24	23,85
6	50	23,8	24	23,9
7	55	24,5	24,7	24,6
8	60	25	25,2	25,1
9	65	25,4	25,6	25,5
10	68	25,7	25,8	25,75
11	70	25,8	26	25,9
12	75	26,4	26,2	26,3
13	80	26,6	26,7	26,65

Water was heated up to 80 °C and cooled down to 25 °C. Capacitance was measured between the two electrodes using an RLC bridge meter model GW 8/5 B, 200 kHz, with capacitance uncertainty of ± 0.2 pF. Temperature was measured at $\Delta T = 5$ °C with a thermometer with uncertainty of ± 0.5 °C. Water was constantly mixed to homogenize the temperature. The voltage signal from the electronic circuit was measured with a digital oscilloscope model Tectronix TDS 3034, 300 MHz/2.5 GS/s, with an uncertainty of ± 0.001 mV. Table 1 shows the outlet capacitance of demineralized water as a function of temperature, and Fig. 5 show the calibration curve behavior for the temperature range from 55 °C to 80 °C. The temperature range mentioned was choice by the realistic operational condition of the capacitance sensor on the natural circulation circuit and because the probability of occur subcooled boiling and eventually some vapor bubble in the test section.

The average pure gas (air) capacitance measured on the test section at 25 °C was 4.5 pF and the average pure liquid (demineralized water) capacitance measured at 25 °C was 25 pF. Considering that the air capacitance dos not change considerably with temperature, and correcting the water capacitance as a function of the temperature by the correlation obtained with Fig. 5, the calibration curve can be obtained by associating the dimensionless capacitance and the dimensionless voltage signal from electronic circuit as follows:

$$C^* = f\left(\frac{V_x - V_G}{V_L - V_G}\right) \quad (6)$$

where, V_x is the voltage signal from electronic circuit for a given void fraction, V_G is the voltage signal from electronic circuit for gas filled, and V_L is the voltage signal from electronic circuit for pure liquid filled.

In Fig. 6, the voltage signal was correlated with capacitance using a static capacitance calibrator. It consists in an association of different capacitors into a range of pure air and pure water capacitance range. The capacitors were of polyester type, characterized to have very low influence of temperature.

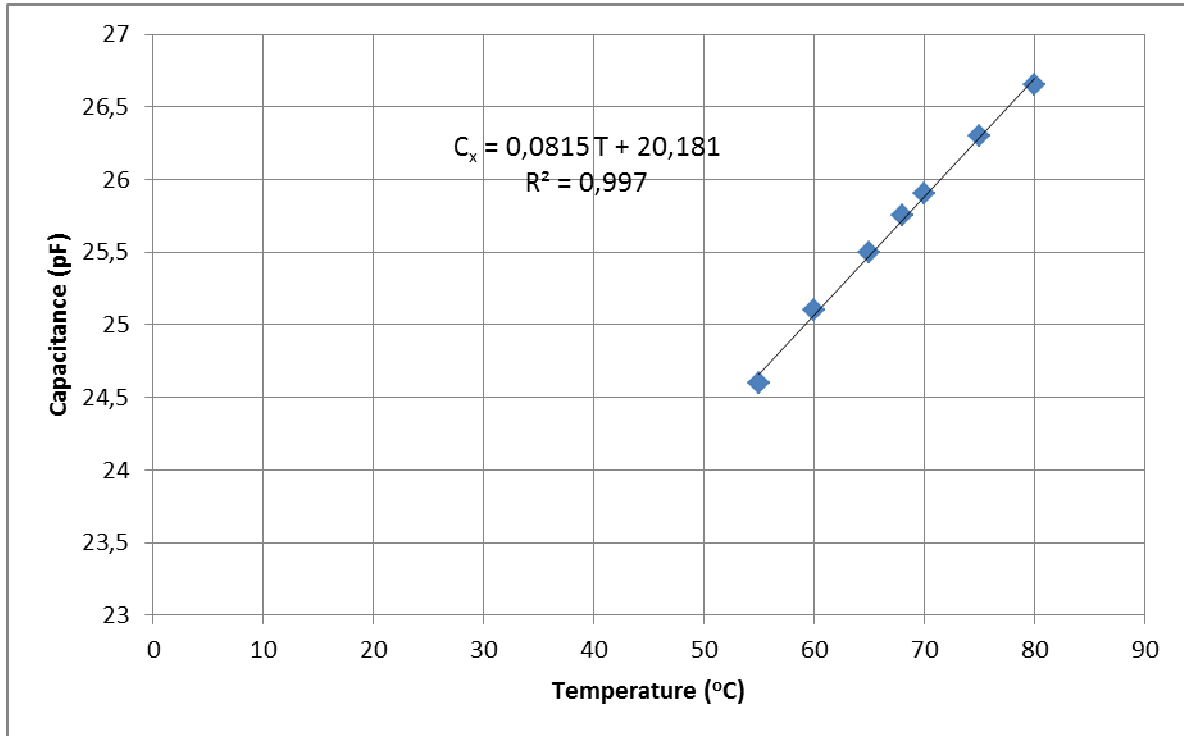

Figure 5. Demineralized water capacitance variation as a function of temperature.

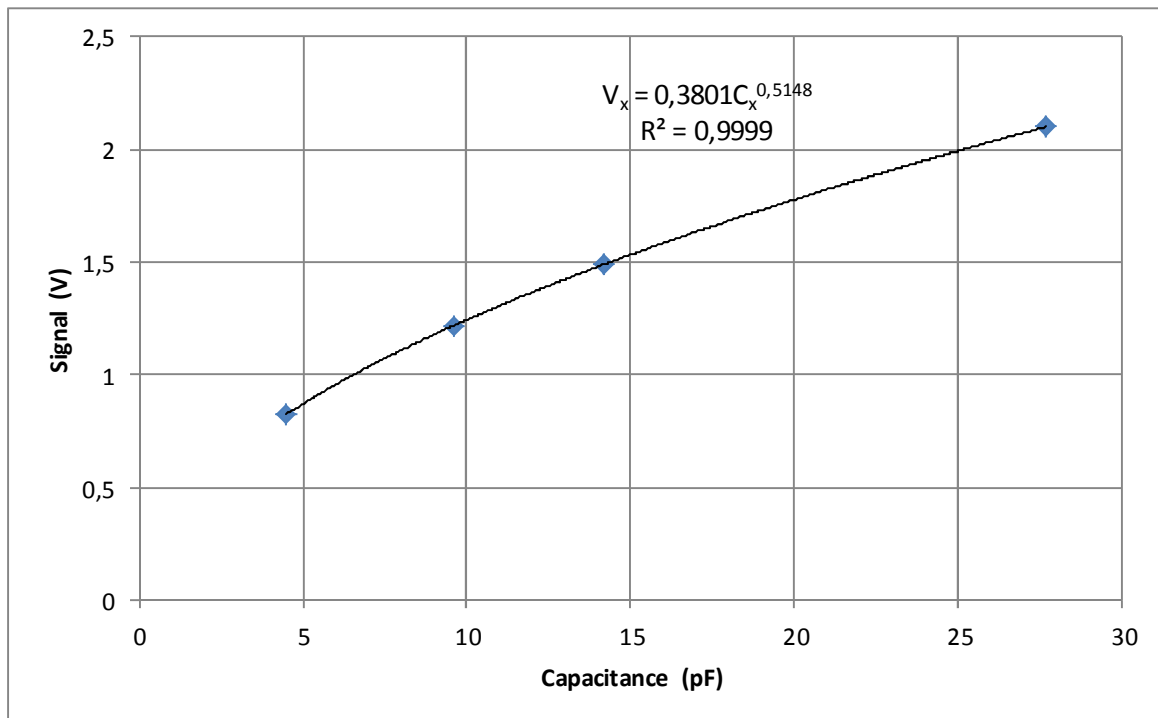

Figure 6. Capacitance sensor outlet signal variation with temperature.

The next step on sensor development is to make it available to the void fraction measurement on the natural circulation circuit by carrying out the dynamic calibration or the calibration with vapor-water or air-water flowing into the test section. A special test section has been mounted to permit the use the quick closing valve calibration technique. It will permit to obtain more realistic void fraction values, and more realistic calibration curve.

5. CONCLUSIONS

The present work shows the design, construction and preliminary tests of a capacitance sensor for void fraction measurement in a prototype of a natural circulation refrigeration loop designed to simulate a nuclear reactor cooling circuit. The capacitance sensor has being designed to measure bulk void fraction on a vertical upward two-phase flow section, and previous results show that it has enough sensitivity to detect the void fraction with uncertainty level sufficient to compare results with the data obtained by simulations.

The temperature influence over the fluid capacitance was verified by obtaining a capacitance versus temperature calibration curve for demineralized water. The voltage signal versus different capacitance values was obtained using a static calibration into the air-water capacitance range.

Next research step consist on sensor dynamic calibration to obtain a well-adjusted calibration curve and tests to form a data bank that will permit comparisons and data use by the simulation techniques used in the project.

ACKNOWLEDGMENTS

The authors wish to acknowledge the CNPq (Brazilian Counsel for Research and Development) for the personal and research funding. Authors appreciate the valuable collaboration of Renato L. França and Samuel C. Santos from CEN/IPEN/CNEN.

REFERENCES

1. Inada, F., Furuya, M., and Yasuo, A., “Thermo-hydraulic instability of Bowring natural circulation loop induced by flashing (analytical consideration)”, *Nuclear Engineering and Design*, **Vol. 200**, pp. 187-199 (2000).
2. Furuya, M., Inada, F., and van der Hagen, T.H.J.J., “Flashing induced density wave oscillations in natural circulation BWR – mechanism of instability and stability map”, *Nuclear Engineering and Design*, **Vol. 235**, pp. 1557-1569 (2005).
3. Hart J.E., “A new analysis of the closed loop thermosyphon”, *Int. Journal of Heat and Mass Transfer*, **Vol. 27**, pp. 125-136 (1984).
4. Geraets, J.J.M., and Borst, J.C., “A capacitance sensor for two-phase void fraction measurement and flow pattern identification”, *Int. Journal of Multiphase Flow*, **Vol. 14**, pp. 305-320 (1998).
5. Jaworek, A., Krupa, A., and Trela, M., “Capacitance sensor for void fraction measurement in water/steam flows”, *Flow Measurement and Instrumentation*, **Vol. 15**, pp. 317-324 (2004).
6. Abouelwafa, M.S.A., and Kendall, E.J.M., “The use of capacitance sensors for phase percentage determination in multiphase pipelines”, *IEEE Transactions Instrumentation Measurement*, **Vol. 29**, pp. 24-27 (1980).
7. Rocha, M.S., and Simões-Moreira, J.R., “Void fraction measurement and signal analysis from multiple-electrode impedance sensors”, *Heat Transfer Engineering Journal*, **Vol.29**, pp. 924-935 (2008).
8. Rocha, M.S., and Simões-Moreira, J.R., “Comparision of RMS and PDF signal analyses from multiple-electrodes impedance sensors in two-phase flow, *Proceeding of 1o Encontro Brasileiro Sobre Ebulição, Condensação e Escoamento Multifásico Líquido-Gás – EBCEM 2008*, Florianópolis, April 28-29, **Vol. 1**, 8 p. (2008).
9. Dos Reis, E., and Goldstein Jr., L., “A procedure for correcting for the effect of fluid flow temperature variation on the response of capacitive void fraction meters”, *Flow Measurement and Instrumentation*, **Vol. 16**, pp. 267-274, (2005).
10. Tambelini, F., “Estudo experimental e numérico da tomografia elétrica aplicada a sistemas bifásicos, Tese de Doutorado apresentada à Comissão de Pós-Graduação da Faculdade de Engenharia Mecânica, 225 p., (1999).
11. Rocha, M.S., Cabral, E.L.L., and Simões-Moreira, J.R., Capacitance sensor for void fraction measurement in a natural circulation refrigeration circuit, 2009 International Nuclear Atlantic Conference – INAC 2009, Rio de Janeiro, 10 p., (2009).