

main body

**THE OPERATIONAL AND LOGISTIC EXPERIENCE ON TRANSPORTATION OF
BRAZILIAN SPENT FUEL TO USA**

OK
repete

*José Rubens Maiorino, *Roberto Frajndlich, **Martin Mandla ***Werner Bensberg,
***August Renger and ***Karsten Grabow

*Instituto de Pesquisas Energéticas e Nucleares, CNEN/SP
Travessa R, 400 – Cidade Universitária – CEP 05508-900
São Paulo – SP - Brazil

** Nuclear Cargo + Services (NCS)
Rodenbacher Chaussees, 6, D-63457 Hanau, German

*** Gesellschaft für Nuklear-Service (GNS)
Hollestrasse 7 a, 45127 Essen, German

ABSTRACT

A shipment of 127 spent MTR fuel assemblies was made from IEA-R1 Research Reactor located at the Instituto de Pesquisas Energéticas e Nucleares (IPEN-CNEN/SP), São Paulo, Brazil to Savannah River Site Laboratory in the United States. This paper describes the operational and logistic experience on this transportation made by IPEN staff and the Consortium NCS/GNS.

INTRODUCTION

IEA-R1 is a pool type research reactor, moderated and cooled by light water, and utilizing graphite as reflector. The construction is a Babcock & Wilcox design and the first criticality was achieved in September 16, 1957. After initial tests, the reactor started operating at 2 MW. Due to the growth in radioisotope demand, in 1997 after necessary modifications and upgrading process, the power was increased to 5 MW /1/.

Along 40 years of the reactor operation, 127 SFA's had been stored at the facility, 40 in a dry storage and the others 87 were stored inside the reactor pool. As reported in the 21st RERTR /2/, since 1996 the Brazilian Nuclear Energy Commission (CNEN) starts negotiation with DOE to return the SFA's of IEA-R1 Research Reactor to USA. Finally, in 1998, an agreement was achieved between CNEN and DOE and in November 1999; the shipment was realized with success. This paper describes the operational and logistic experience of the SFA's transport.

FUEL INFORMATIONS

The SFA's transported to USA were used in IEA-R1 RR, as follow: the first load corresponds to the first core of the reactor. It was composed of U-Al alloy fuel with 20wt% enrichment, having 19 curved fuel plates produced by B&W. These fuel assemblies failed at the earlier stages of the reactor operation, due to pitting corrosion caused by brazing flux used to fix the fuel plates to the support plates. As the burn up and the dose rate was very low, the assemblies were placed in a dry storage composed by horizontal silos at a concrete wall located at the first floor of the reactor building.

These fuels were replaced, in 1958, by new ones, also produced by B&W. They were identical to the earlier ones (U-Al alloy, 20wt% enrichment, 19 curved fuel plates) but brazing was not used for assembling. The fuel plates were fixed mechanically to the support plates.

The third load corresponds to a complete substitution of the core. Fuel made with U-Al alloy, 93 wt% enrichment, having 18 flat fuel plates were bought from UNC (USA). In the middle of this cycle the control rod mechanical concept was also changed from rod type to fork type (plate type). The control fuel element assemblies were fabricated by CERCA (France), using U-Al alloy, HEU and flat plates.

The fourth load is characterized by the restriction of HEU fuel supply. IPEN bought, from NUKEM (Germany), 5 fuel element assemblies of UAl_x-Al dispersion type, with 20wt% enrichment and having 18 flat fuel plates per fuel element assembly. The SFA's were those, which had been transported back to the United States, and table 1 summarizes its characteristics. All these fuel had been inspected by b Brazilians /3/ and DOE team /4/.

After these loads, all the fuel assemblies used at IEA-R1 were constructed in IPEN although many of them with uranium from USA origin not yet transported.

Table 1 – summarizes of the assemblies used in IEA-R1 reactor core

LOADING	FIRST	SECOND	THIRD	FOURTH
Year	1957	1958	1968	1981
Country	USA	USA	USA/France	German
Enrichment	20	20	93	20
Standard assembly	34	33	33	5
Control assembly	5	4	10	-
Partial assembly	1	2	-	-
Total assembly	40	39	43	5

COMPANIES CONTRACTED FOR THE TRANSPORT OPERATION

The contract between the Nuclear Energy National Commission (CNEN/Brazil) and the Department of Energy (DOE/USA) was signed in 1998. Edlow International Co. and the Germany Consortium formed by Nuclear Cargo + Services (NCS) and Gesellschaft fur Nuklear-Service (GNS) were hired to performed the transport. Tec Radion Comercial Ltda Company (TRION) was subcontracted by Edlow to provide the necessary infrastructure for the loading, transport and customs documents.

The German Consortium provided 4 transport casks (two GNS-11 and two GNS-16), a transfer cask, equipment and experts to handling their equipment. IPEN/CNEN-SP performed the work necessities to accomplish the Brazilian legislation as the export license, a detailed Transport and Security Plan, safeguards documents, the Appendix A and so on, as well as operational and radiological protection support to the entire operation.

TRANSPORT EQUIPMENT DESCRIPTION /5//6/

The transport cask GNS 16 (see Fig. 1) is designed in a sandwich construction. The cylindrical cask basically consists of the following components: inner liner with inner liner bottom, lead filling, wall with bottom plate, side wall cover sheet with spacer wire, head ring, primary lid and protective plate. The maximum weight of the cask is 13230 kg.

The components of the cask body and the primary lid are manufactured in stainless steel. In the terms of the transport regulations, the "leak-tight containment" consists of the inner liner, the inner bottom plate, head ring, primary lid with the bolt joint and the inside seal of the two Viton seals arranged concentrically and the closure lid in the primary lid, including the bolt joint and the inside seal of the two Viton seals arranged concentrically.

Cap screws are used in order to fasten the primary lid. The closure lid is also fastened to the primary lid using cap screws. In order to achieve the shielding effect, the space between the inner liner and the shell is filled with lead casting. A pair of trunnions is bolted on to the head ring in order to attach handling devices. During transport, the cask is provided with a protective plate. In order to reduce the shock loads arising during the drop tests stipulated for type B packaging, impact limits made of wood with a steel-plates shell are attached to the ends of the cask body on the lid and bases sides. Because of the different geometry of the fuel assemblies to be transported, the inner cavity of the cask can accommodate one of each of the three following baskets: FR 2/33 to accommodate 33 box-shaped FE's, FR 2/28 to 28 tubular FE's and FR 2/15 to 90 rod-shaped TRIGA FE's. The GNS 11 cask is similar to GNS 16. A summary of the characteristic data for fissile material and burn-up used for box-shaped MTR FE is showed in the table 2.

FUEL CUTTING EQUIPMENT

Before the beginning of the loading operation, 19 control fuel assemblies were cut 1.27 cm from the cut line to the interior fuel plates. This cut was necessary due to the cask length limitation and the SRS request. The cutting operation of five control fuel assemblies stored in the dry-

storage was performed in the first floor of the reactor building. A conventional saw normally used for aluminum profile cut was utilized. The assemblies were manually removed, one by one, from the carbon steel piping of the dry storage and placed in a lead shielding. A second technician cut the plastic that was involving the assembly and took it to the saw for the cutting. The cutting pieces were put in a special place as waste and the assembly was stored again. This operation was possible due the low burn up and dose rate of these SFA's.

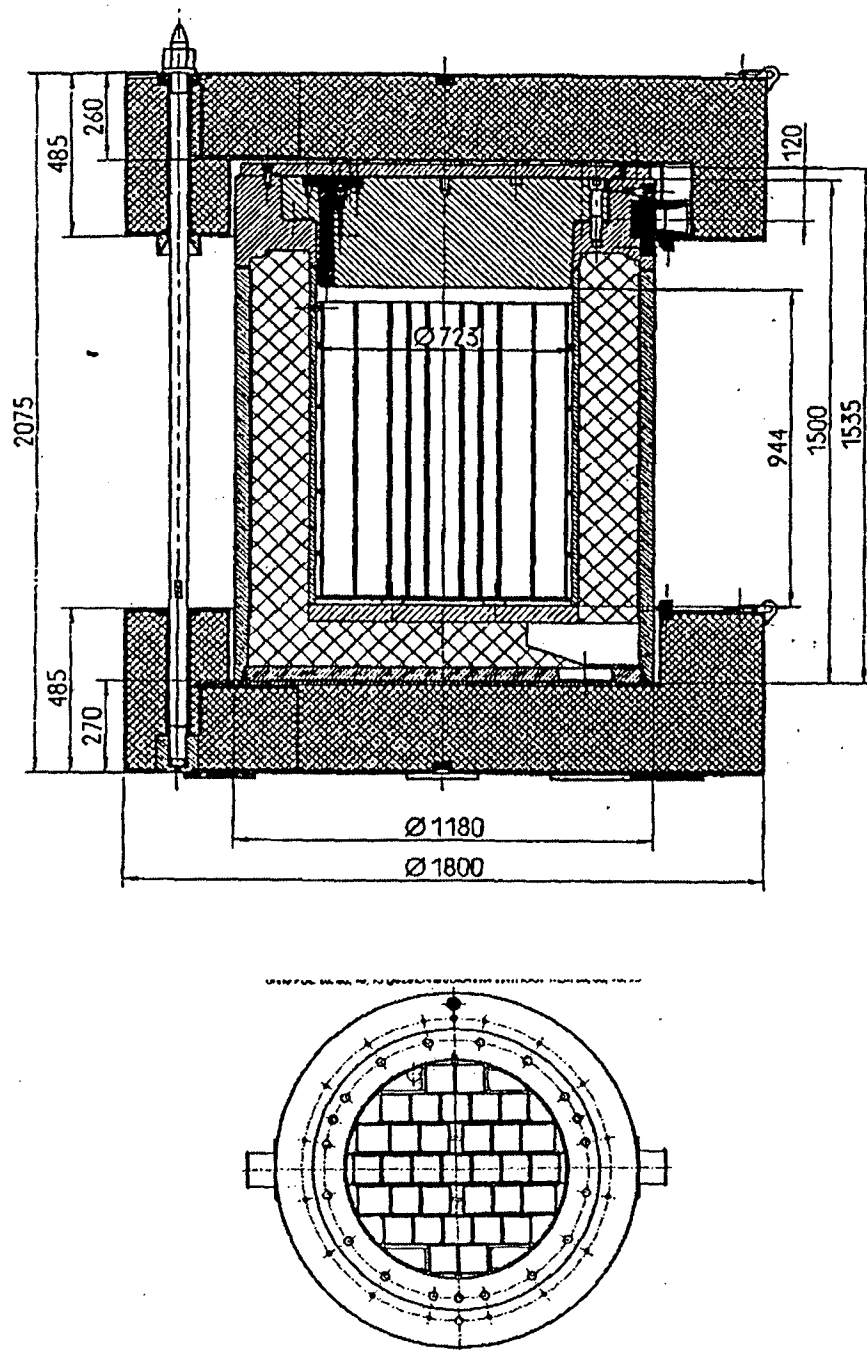

Figure 1 – GNS 16 cask

For the cutting of the 14 SFA's stored in the reactor pool, it was used an underwater saw machine specially designed and constructed in Brazil under supervising of Edlow/Trion (see Figure 2). This saw machine was positioned 2.5 meters below the surface of the water inside an aluminum box cover by an acrylic sheet. The saw was of stainless steel construction with an electrical motor that remained above the surface of the pool and was controlled from poolside. The assembly was fixed pneumatically inside the aluminum box.

Table 2 – Characteristic data for Fissile Material and Burn-up – box shaped MTR-FE

	GNS-11	GNS-16
Max. Number of FE per cask	33	33
Max. FE length, mm	630	915
Max. FE cross section, mm ²	81 x 76.1	84 x 77
Max. FE mass, kg	2.65	7.0
Min. Cooling time	180 days	> 1.5 years
Max. Initial enrichment, weight % of ²³⁵ U	94	95.1/HEU 45.7/MEU 20.3/LEU
Max. Initial weight of ²³⁵ U,g	268	459/HEU 328/MEU 420/LEU
Max. Burn-up, MWd/FE		184/HEU 181/MEU 222/LEU
Max. decay heat, W	48.5	40
Max. FE length, mm	610	-
Max. activity (x E14 Bq)	3.3E02	6.3E2

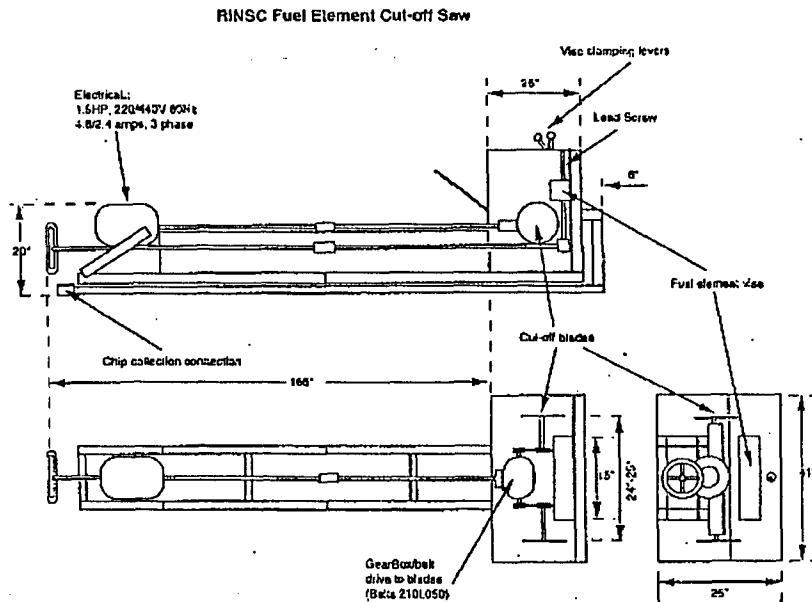

Figure 2 – Under Water Cutting Machine

LOADING AND TRANSPORT DESCRIPTION

On September 16, four containers with two GNS-11 German casks and equipment arrived at IPEN. The two GNS-16 casks arrived in IPEN on October 7. German experts supported by IPEN technician and the transportation company staff hired by Edlow/Trion removed the equipment from the containers and placed on a truck, which were transported to the reactor building. With the help of a crane with 25-ton capacity, equipment were placed on an iron platform located in front of the access hall of the building. With the help of a mobile lift, the platform was moved inside of the reactor building and positioned under the access to the 3rd level (pool surface). Part of the equipment, as the transfer cask, primary lid, water tank and so on were lifted by the reactor mobile crane with 10 ton capability until the 3rd level; In the same way, the cask was moved inside the reactor building and positioned in the first level, under the access to the 3rd level.

On September 21, the primary lid was removed from the GNS-11 cask and lifted to the 3rd level. The rotary lid was positioned in the upper part of the cask and a cold test with a dummy element was made by the Brazilian and German teams. A transfer cask, 4-ton weight was used to transfer the assemblies from the wet storage to the transport cask. The SFA's, one by one, were lifted from the storage racks inside the reactor pool with a special tool and positioned inside a plastic tube located on a metallic plate form located at 2 meters from the pool surface. The transfer cask was sunk inside the reactor pool over the assembly to be removed. A special tool took the assembly and put it inside this cask, which was lifted by the reactor mobile crane and positioned upper, the rotary lid and transport cask located in the first level (see figure 3). Finally, the assembly was guided to one of the 33 positions of the cask. In order to remove the rotary lid and put the primary lid, after cask loading, a water tank was positioned upper the cask and filled with 4000 liters of water. Finally, the cask was closed and the water was drained from it and from the water tank.

This operation was repeated for the 87 assemblies stored in the wet storage. For the others 40 SFA's stored in the dry storage, the transfer cask was not used. Instead of it, a water tank was positioned in the upper part of the cask and the operation was performed as follow: the SFA's were taken from the storage, one by one, by hand, and put in a cylindrical lead shield positioned besides the cask. An operator located in the 3rd level, using a nylon rope with a hook in its extremity lifted the SFA and put it inside the water tank. Finally, the operator guided the SFA visually to the final position in the transport cask.

On October 15 the four GNS casks were loaded with the 127 Brazilian spent fuel assemblies. Then, the decontamination procedures were performed.

On October 20 and 21 all the equipment and cask were removed from the reactor building to the containers. The casks were stamped and controlled by safeguards inspectors from ABACC (Brazilian-Argentine Agency for Accounting and Control of Nuclear Materials) supervised by IAEA.

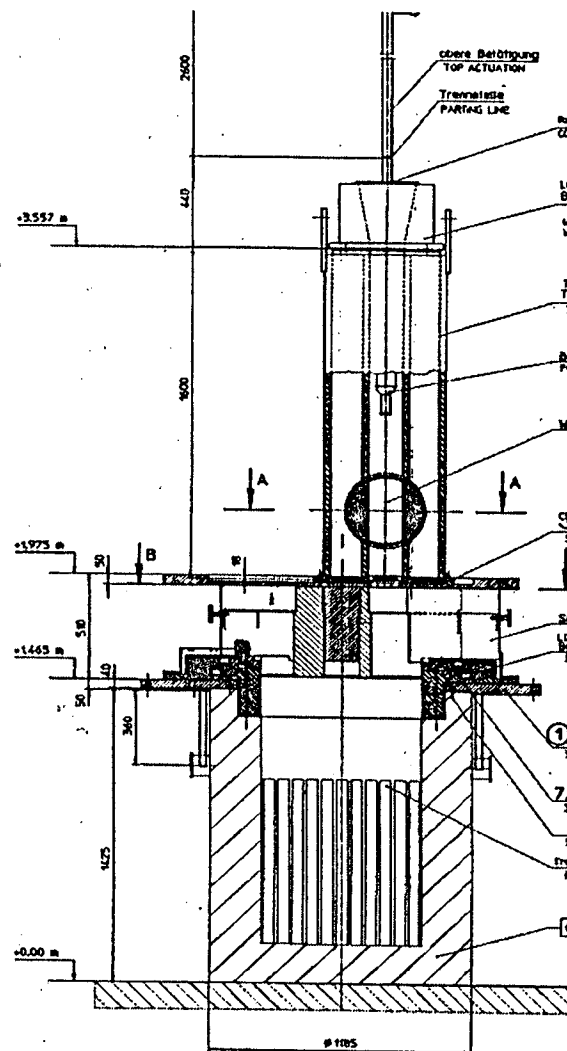

Figure 3 – View of the transfer cask used to transfer the assemblies to the transport cask

On November 3, the transport operation was initiated after approvals from the Brazilian regulatory bodies (Nuclear and Environmental) had been obtained by IPEN. The licenses were issued by CNEN and IBAMA (Environmental Brazilian Agency), which required documents of transport, radiation and physical protection as well as an evaluation of the environmental impact. Also the GNS 11 and GNS 16 certificates issued by American and German authorities had to be revalidated in Brazil. It is worthwhile to mention that to obtain these licenses, an enormous effort was done by IPEN staff. Also opposition from Greenpeace, local politicians and harbor union demanded a political work to overcome this opposition and avoid legal prosecute against the operation, including debates and press clearance.

On November 4 at down a huge convoy consisting of 4 trucks escorted by Federal, State and County Police arrived in the port of Santos. It is also worthwhile to mention that the Highway

and the main avenues and streets in São Paulo and Santos had been closed for circulation during the operation. At 2h10min am, it was started the shipment of the containers and concluded after 42 min. Before and during all shipment the workers had been monitored by IPEN radiation protection staff. At 4h50min am, the ship left the port escorted by boats of the federal police. In the exit of the port, these boats were substituted by a frigate of the Brazilian Navy, which followed the ship until a distance of 200 miles away from the Brazilian coast.

Cs LEAKING RATE AND SEALING SYSTEM OF THE CASKS /5//6/

Two tests were performed after the casks loading. The first one was to evaluate the ^{137}Cs leaking rate inside the cask. In order to perform this test, three water samples were taken from each cask after 0, 4 and 12 hours. The water sample was collected in a small plastic bottle (1500 ml) and submitted to gamma-ray spectrometry analysis. All bottles used for sampling were identical. The results of this test is showed in table 2.

Table 2 - ^{137}Cs leaking rate in the casks after 12 hours

Cask	sample 1 dpm/ml	Sample 2 dpm/ml	sample 3 dpm/ml
GNS11-1	1.24	1.86	3.96
GNS11-2	27.6	12.8	24.0
GNS16-1	1.48	14.0	24.6
GNS16-2*	233.8	875.1	743.3

Obs. limit value for the GNS < 992 dpm/ml

* this cask was loaded with the SFA's stored in the dry-storage

A second test was performed in order to verify the sealing system. The primary lid and the protective caps with their screws and testable O-rings are decisive for guaranteeing the retention of the inventory. Grooves are turned into the primary lid in order to accommodate two O-ring seals on the bottom sides of the lid flanges. The O-ring, which is part of the containment boundary, is insert into the inner groove on the primary lid. The O-ring inserted in the outer groove is not component of the containment boundary. No account is taken of its sealing effect. It forms a testing volume for the leak test. Each protective cap has a groove to accommodate the respective O-ring of the containment boundary.

The leak tightness of the primary lid is proven with a pressure-drop test via the testing connection "B" of the O-rings of the primary lid. For the protective caps the pressure drop tests is performed on a test volume built by a test adapter covering each cap. The measured leakage rate thus is the combination of leakage through both O-rings or other seals forming the boundary of each test volume. The leakage rate for the O-rings, which are part of the containment boundary, thus in reality is lower than the measure value. However, this is ignored for the following calculation, and the specified value of the sealing assigned to the O-rings, which are part of the containment boundary.

As a consequence of Type B tests no systematic deterioration of the sealing characteristics must be assumed. This was proven by tests on transport casks with a comparable sealing system. For the transport cask GNS 11 this test is the guarantee that during and after the Type B tests, the

leakage rate specified for normal conditions of transport will not be exceeded. For the GNS 16, the test is similar. Results are showed in table 3.

Table 3 – Sealing system test

Cask	Test n° 1 hPa.l.s ⁻¹	Test n° 2 hpa.l.s ⁻¹	Test n° 3 hPa.l.s ⁻¹
GNS11-1	9.1E-06	9.6E-06	1.9E-05
GNS11-2	2.1E-06	9.9E-06	3.2E-06
GNS16-1	8.4E-06	1.2E-07	-
GNS16-2	7.0E-07	1.9E-06	-

Limit value for the GNS11 < 1.0 E-04 HPa.l.s⁻¹

Limit value for the GNS16 < 2.0 E-05 HPa.l.s⁻¹

CONCLUSIONS

IPEN-CNEN/SP considered that the loading operation, shipment and transport were performed with success once it occurred without any incident and the 127 spent fuel assemblies burned in the reactor IEA-R1 in the last 40 years were loaded and transported to Santos as planned in the Transport and Security Plans. Also, all the loading operation was successfully achieved due to the professional and friend relationship between the Brazilian and German team.

REFERENCES

- /1/ Maiorino, J.R; Perrotta, J.A; Frajndlich, R.; “The Conversion and Power Upgrading of IEA-R1: Experience and Perspectives”, in 21st RERTR, October 18-23, 1998, São Paulo, Brazil.
- /2/ Frajndlich, R.; Perrotta, J.A; Maiorino, J.R; Soares, A.J.; “Experience of IEA-R1 Reactor Spent Fuel Transportation back to USA”, in 21st RERTR, October 18-23, 1998, São Paulo, Brazil.
- /3/ Perrotta, J.A; Terremoto, L.A.A.; Zeitune, C.A. “Experience on Wet Storage Spent Fuel Sipping at IEA-R1 Brazilian Research Reactor” – IPEN/CNEN-SP Technical Meeting in Budapest, Hungary (October/1996).
- /4/ A Team of personnel from WSRC, DOE-SR, SAIC and INEL. “Characterization of IEA-R1 Spent Nuclear Fuels at the IPEN, São Paulo, Brazil, July 22 – July 31, 1996” – Internal report.
- /5/ Application Documents for the Transport Licensing of the Type B (U) F Package Transport Cask GNS11. Gesellschaft fur Nuklear-Behalter mbH (GNB).
- /6/ Application Documents for the Transport Licensing of the Type B (U) F Package Transport Cask GNS16. Gesellschaft fur Nuklear-Behalter mbH (GNB).

ACKNOWLEDGEMENT

The Brazilians authors wish to express their thanks to NCS/GNS for the financial support to participate in the RERTR 2000.

THIS PAGE LEFT BLANK INTENTIONALLY

meta

ANL/TD/TM01-12

Technology Development
Division
Technology Development
Division
Technology Development
Division
Technology Development
Division
Technology Development
Division
Technology Development
Division
Technology Development
Division
Technology Development
Division
Technology Development
Division
Technology Development
Division
Technology Development
Division
Technology Development
Division
Technology Development
Division
Technology Development
Division
Technology Development
Division
Technology Development
Division
Technology Development
Division
Technology Development
Division
Technology Development
Division
Technology Development
Division

Proceedings of the 2000 International Meeting on Reduced Enrichment for Research and Test Reactors

by Armando Travelli

Reduced Enrichment for Research
and Test Reactors Program
Technology Development Division

22/6, Las Vegas, USA

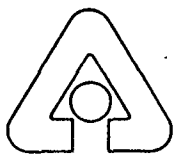

Argonne National Laboratory, Argonne, Illinois 60439
operated by The University of Chicago
for the United States Department of Energy under Contract W-31-109-Eng-38

Technology Development
Division
Technology Development
Division
Technology Development
Division
Technology Development
Division

Argonne National Laboratory, with facilities in the states of Illinois and Idaho, is owned by the United States Government and operated by The University of Chicago under the provisions of a contract with the Department of Energy.

DISCLAIMER

This report was prepared as an account of work sponsored by an agency of the United States Government. Neither the United States Government nor any agency thereof, nor The University of Chicago, nor any of their employees or officers, makes any warranty, express or implied, or assumes any legal liability or responsibility for the accuracy, completeness, or usefulness of any information, apparatus, product, or process disclosed, or represents that its use would not infringe privately owned rights. Reference herein to any specific commercial product, process, or service by trade name, trademark, manufacturer, or otherwise, does not necessarily constitute or imply its endorsement, recommendation, or favoring by the United States Government or any agency thereof. The views and opinions of document authors expressed herein do not necessarily state or reflect those of the United States Government or any agency thereof, Argonne National Laboratory, or The University of Chicago.

Available electronically at <http://www.doe.gov/bridge>

Available for a processing fee to U.S. Department of Energy and its contractors, in paper, from:

U.S. Department of Energy
Office of Scientific and Technical Information
P.O. Box 62
Oak Ridge, TN 37831-0062
phone: (865) 576-8401
fax: (865) 576-5728
email: reports@adonis.osti.gov



TC
SIC

-> publicação
dentro de um
mês

Memorando Interno DPE n.º 009/2002

DATA: 06 DE NOVEMBRO DE 2002

PARA: MERY P. ZAMUDIO IGAMI - IHD

DE: JOSÉ RUBENS MAIORINO - DIRETORIA DE PROJETOS ESPECIAIS

Assunto: SOLICITAÇÃO DE ARTIGO

Em atenção ao seu e-mail, informo que esse trabalho foi oficialmente publicado como Relatório Argonne National Laboratory, Argonne, Illinois 60439 operated by The University of Chicago for the United States Department of Energy Under Contract W-31-109-Eng-38 - ANL/TD/TMO1-12, conforme cópia anexa.

Atenciosamente,

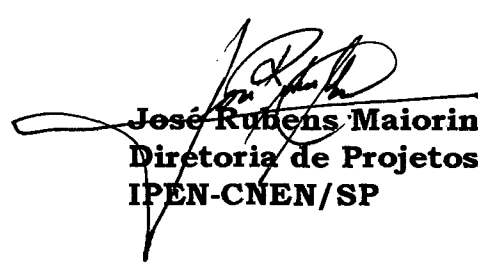
José Rubens Maiorino
Diretoria de Projetos Especiais - DPE
IPEN-CNEN/SP

c/c: arquivo