

THERMAL HYDRAULICS SPECIAL THEME FOR CFD CODES THERMAL STRATIFICATION EXPERIMENTS

**Delvonei A. Andrade, Gabriel Angelo, Antonio Belchior Junior, Edvaldo Angelo,
Pedro E. Umbehaun, Gaiane Sabundjian, Walmir M. Torres, Luiz A. Macedo**

Instituto de Pesquisas Energéticas e Nucleares (IPEN / CNEN - SP)
Av. Professor Lineu Prestes 2242
05508-900 São Paulo, SP

delvonei@ipen.br; gabriel.angelos@gmail.com; abelchior@ipen.br; edvaldo.angelo@gmail.br;
umbehaun@ipen.br; gdjian@ipen.br; wmtorres@ipen.br; lamacedo@ipen.br

ABSTRACT

The analysis of a thermal stratification experiment was proposed as a XVII ENFIR Special Theme. In this experiment, cold water at 28 °C is injected in the circuit which is filled with hot water at 221 °C at 2.14×10^6 Pa. CFD simulations were performed. Stratification and mixing were captured by the model. Results are presented in order to provide material for comparisons with the results of other simulations by different groups and also comparison with the experimental data.

1. INTRODUCTION

A CFD model was develop in order to attend the task proposed by Rezende et al. [1] as a Special Theme in XVII ENFIR.

The model was developed using ANSYS-CFX[®] [2] considering as many numerical tips as possible [3,4,5,6,7]. The following characteristics are in the numerical model:

Domain: The domain was constructed using the information provided by the special theme group. Figures 1, 2 and 3 show the complete domain (symmetry), complete domain and a detail of the tube inside the steam generator vessel, respectively.

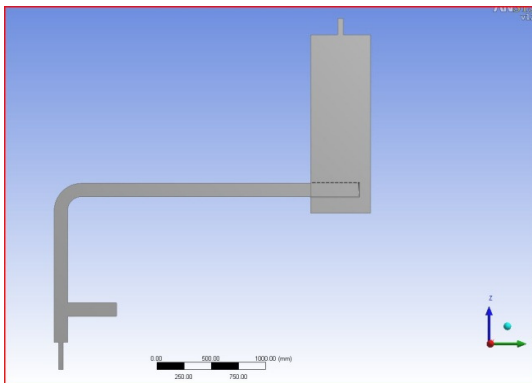

Figure 1 – Geometrical model (Symmetry)

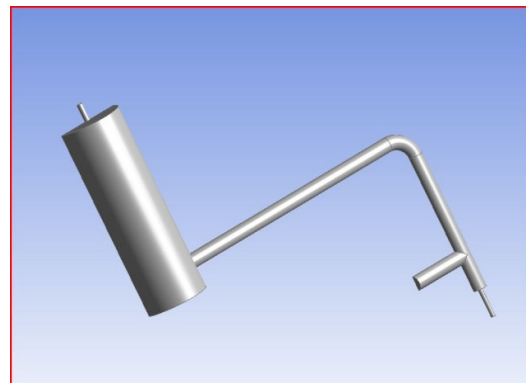

Figure 2 – Geometrical model

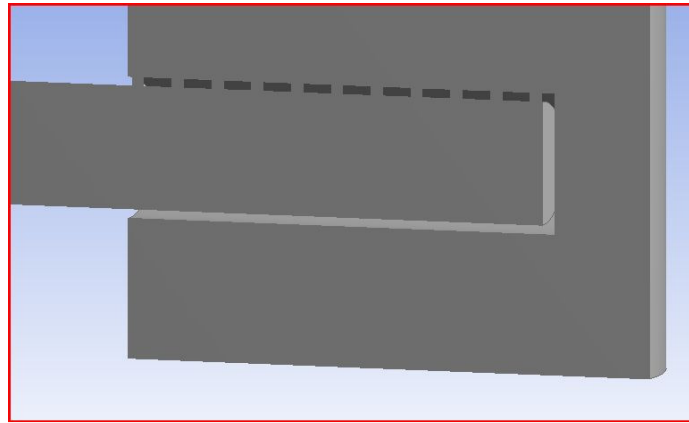

Figure 3 – Detail of the tube inside the steam generator vessel (injection nozzle)

Mesh: Several meshes were tested. A very refined mesh was chosen, however due to the time of the simulations we decided for a more simplified mesh with 414264 elements. Figures 4 to 10 illustrate the mesh.

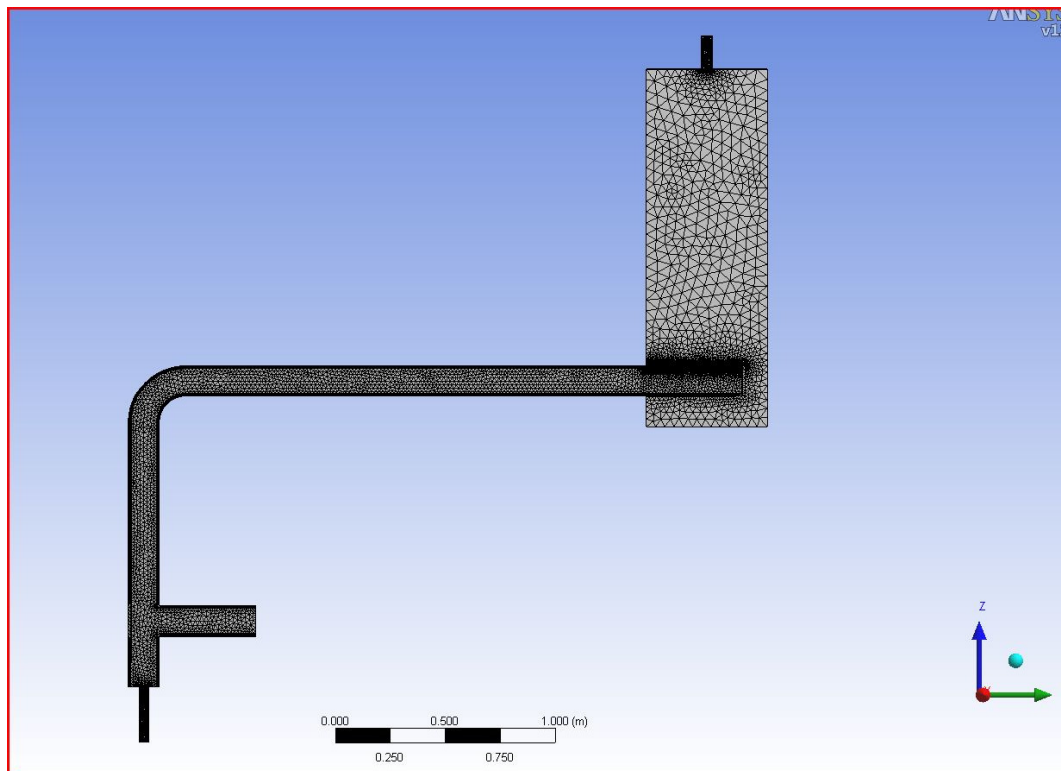

Figure 4 – Mesh (Symmetry region)

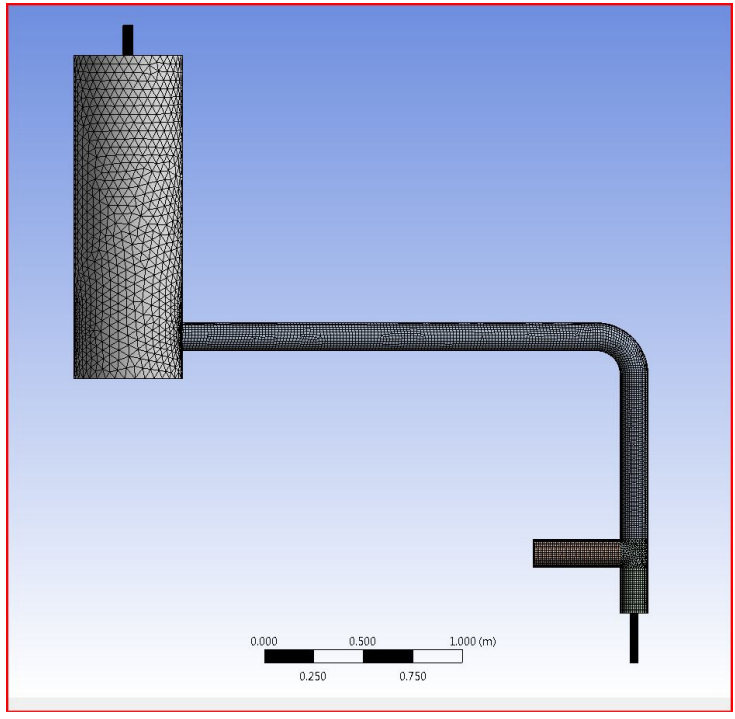

Figure 5 – Mesh (complete geometry)

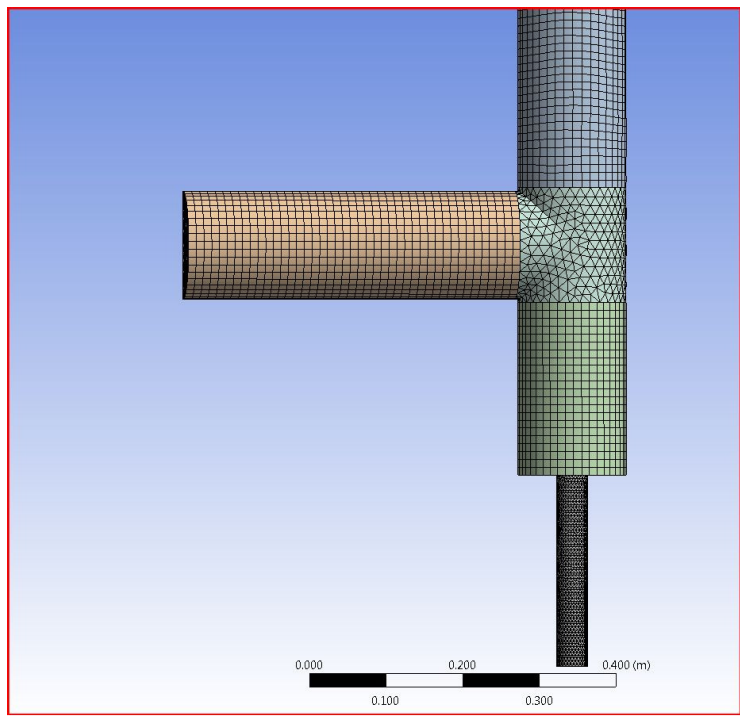

Figure 6 – Mesh (Inlet detail 1)

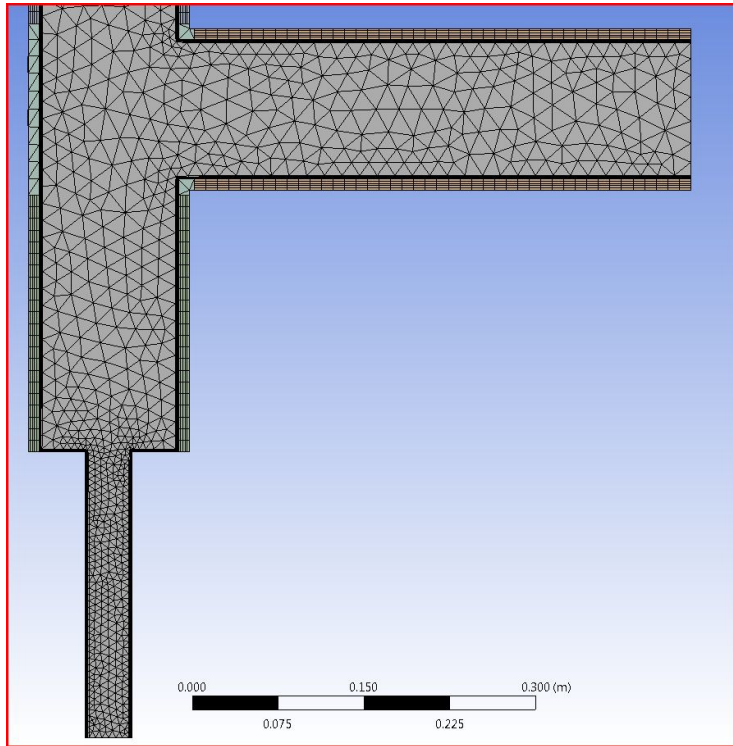

Figure 7 – Mesh (Inlet detail 2)

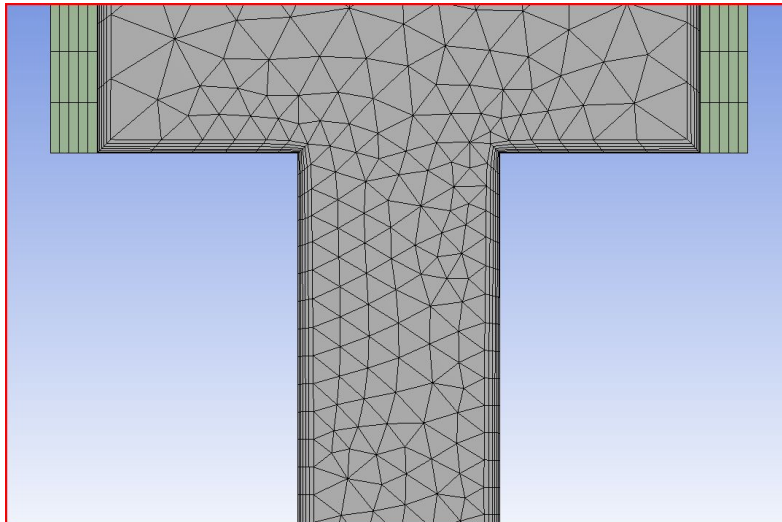

Figure 8 – Mesh (Inlet detail 3)

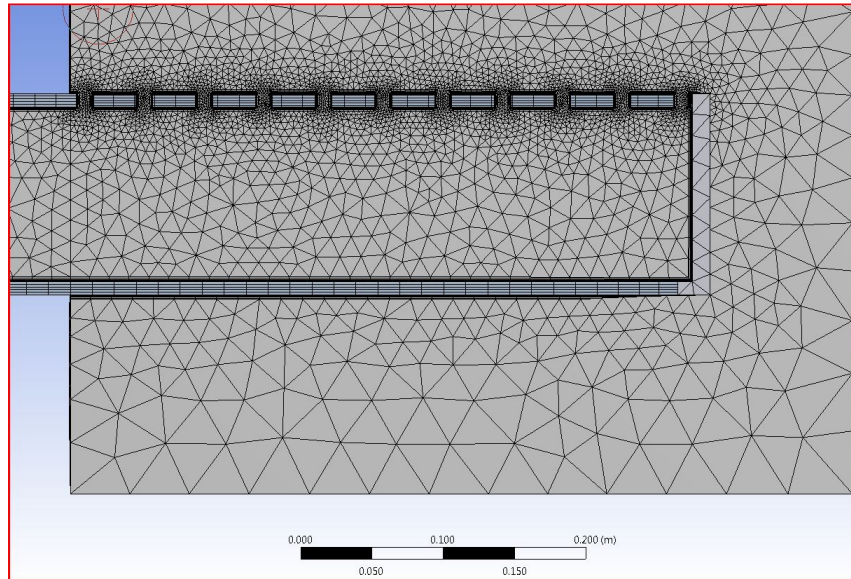

Figure 9 – Detail of the tube mesh inside the steam generator vessel (injection nozzle)

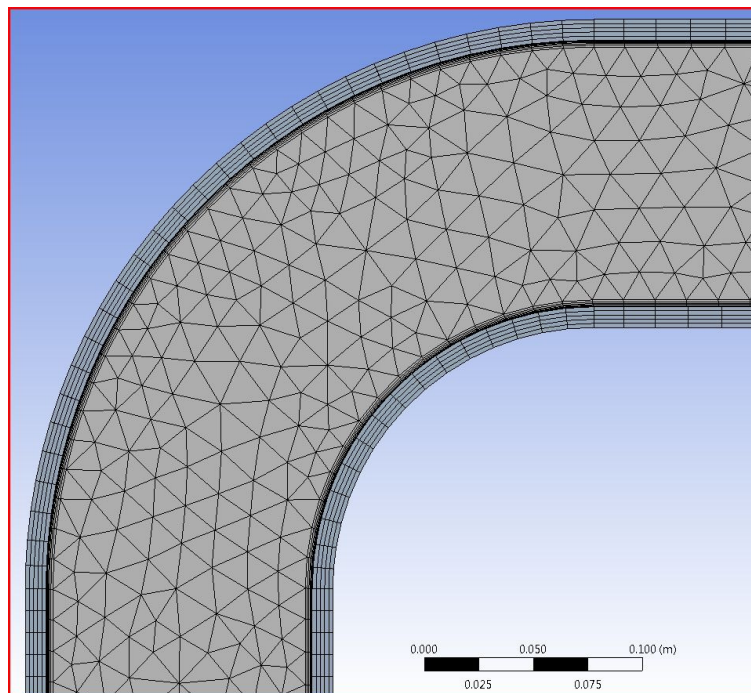

Figure 10 – Detail of the tube mesh

Boundary, initial and set up conditions: The following boundary and initial conditions were used;

- Inter mass flow rate – 1.12 kg/s;

- Outlet pressure – 2.14×10^6 Pa(abs);
- Cold water injection temperature – 28°C and
- Initial system temperature – 221°C .

The standard $\kappa-\varepsilon$ approach and the turbulent buoyancy effects were considered in this model. The time step was set as 0.025 s for a simulation time of 300 s. Redlich-Kwong thermodynamics properties were used. Single precision, 10^{-4} , were used as the solver precision and the convergence criterion, correspondingly. Simulation took, approximately, three and a half days in a Xeon dual processor E5520 family, 2.26GHz, with 48 gigabytes of memory. Advection and transient scheme were calculated with second order terms and second order backward Euler terms, respectively.

2. RESULTS

Results are presented in terms of wall temperature, internal temperature and vertical probe temperatures for the stations I, II and III. Figures 11 to 19 illustrate it. Contour of temperature for 2 s, 25 s, 28.5 s, 50 s and 1000 s are presented in figures 20 to 24 using the same temperature scale which lower limit is 28°C and upper limit is 221°C . Figure 25 shows the velocity field for 28.5 s of simulation. Figure 26 presents a velocity field detail in the region of the tube inside the steam generator vessel (injection nozzle) using the same velocity scale presented in figure 25.

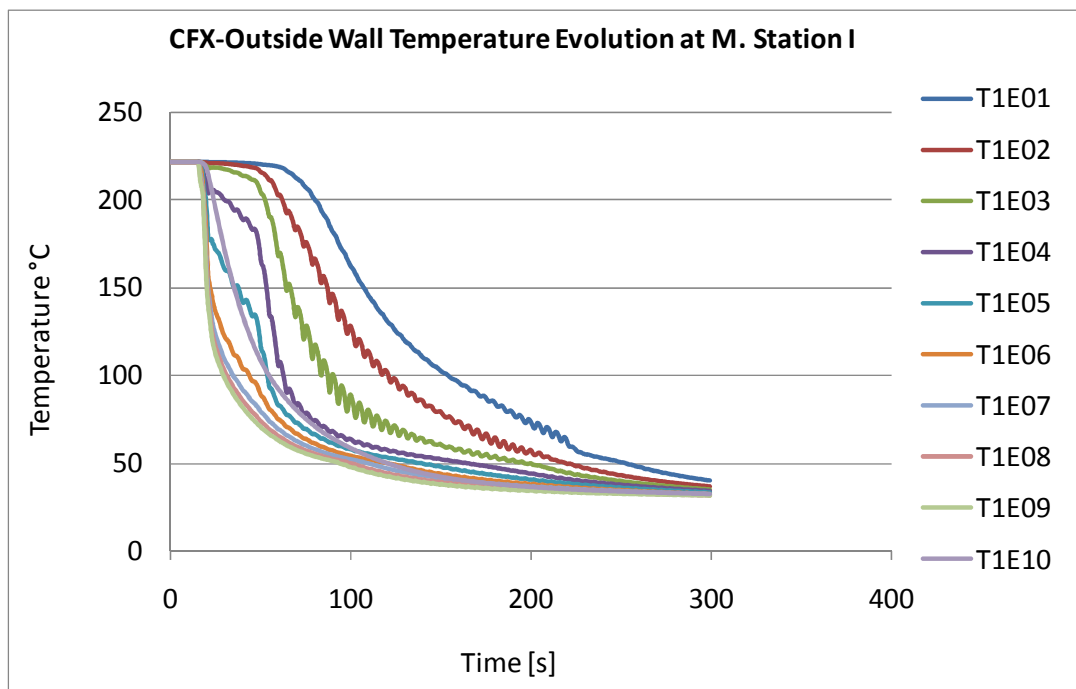

Figure 11 – Wall temperature – Station I

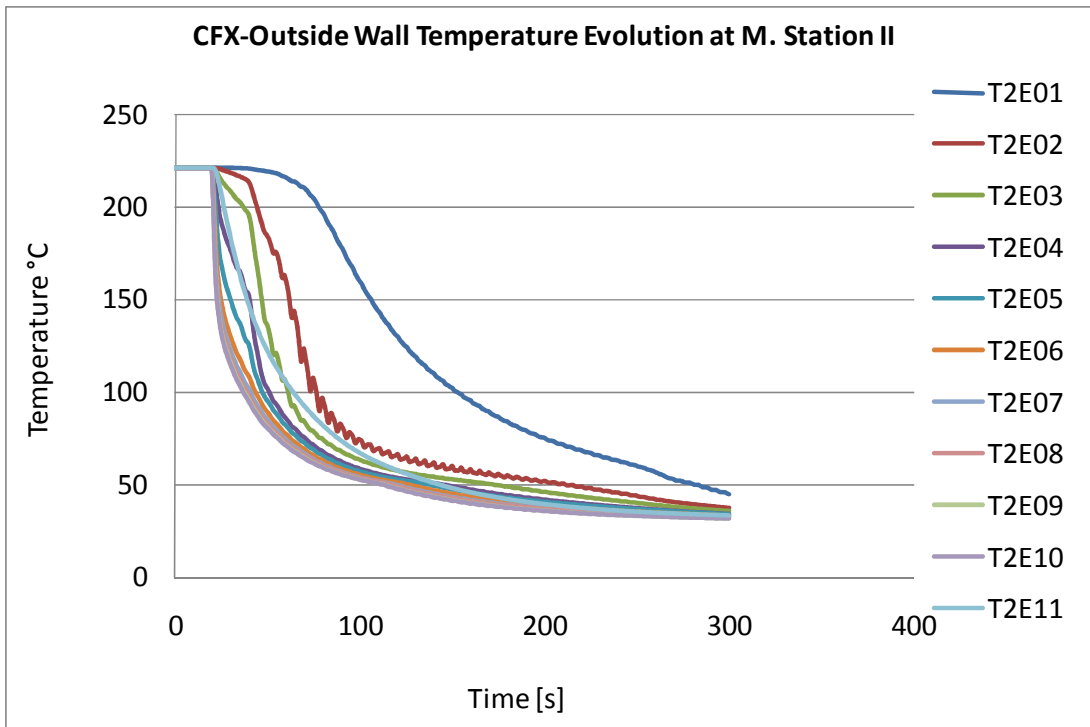

Figure 12 – Wall temperature – Station II

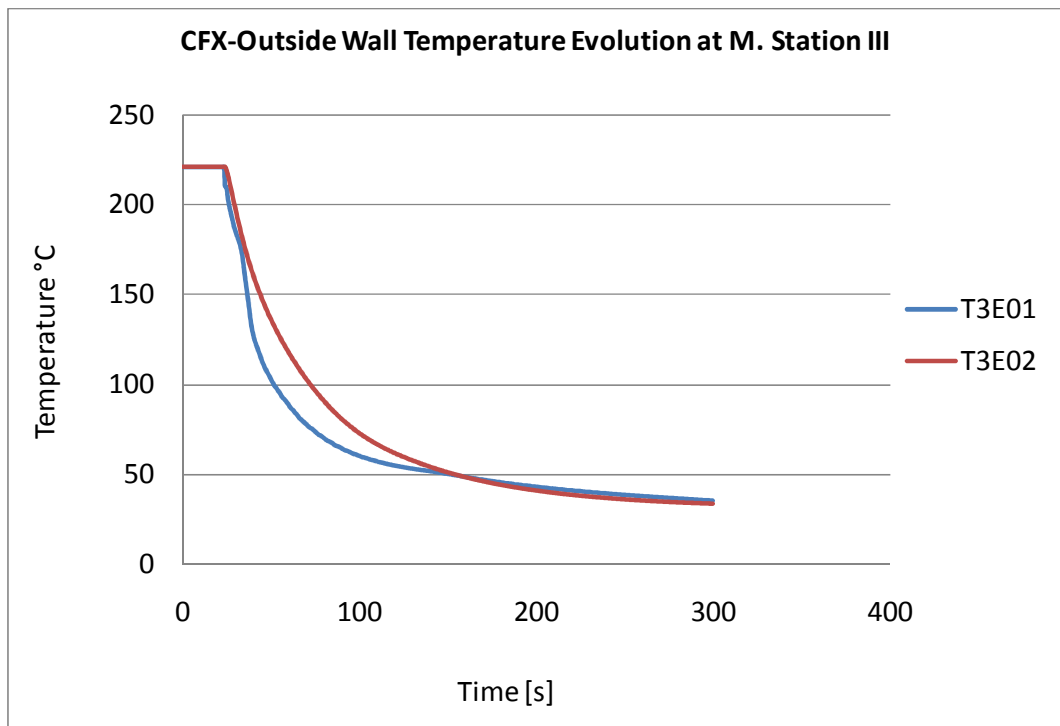

Figure 13 – Wall temperature – Station III

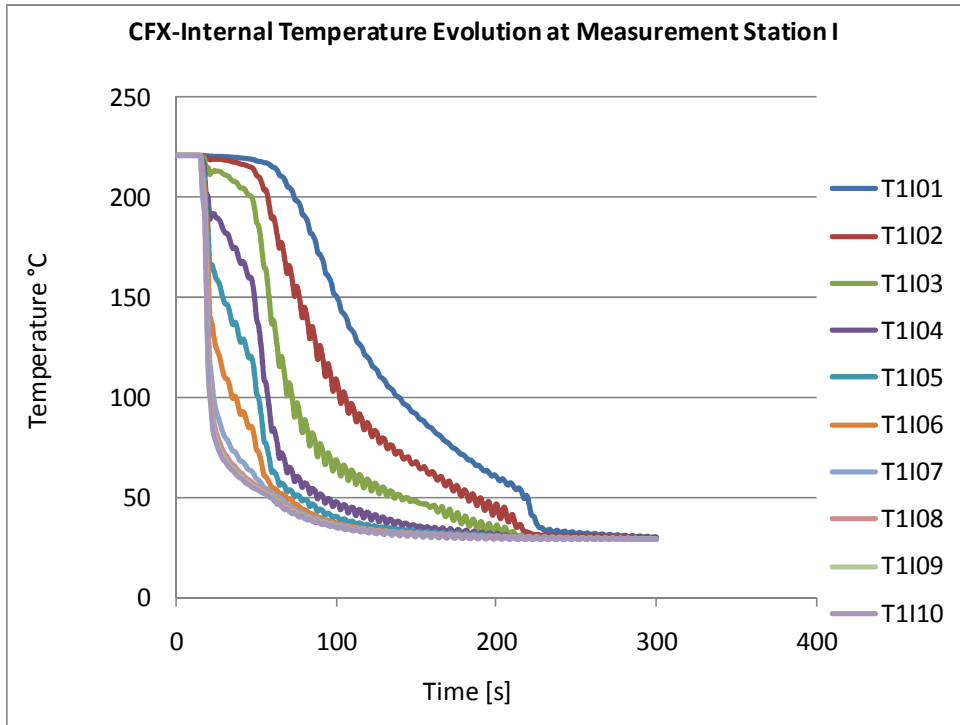

Figure 14 – Internal temperature – Station I

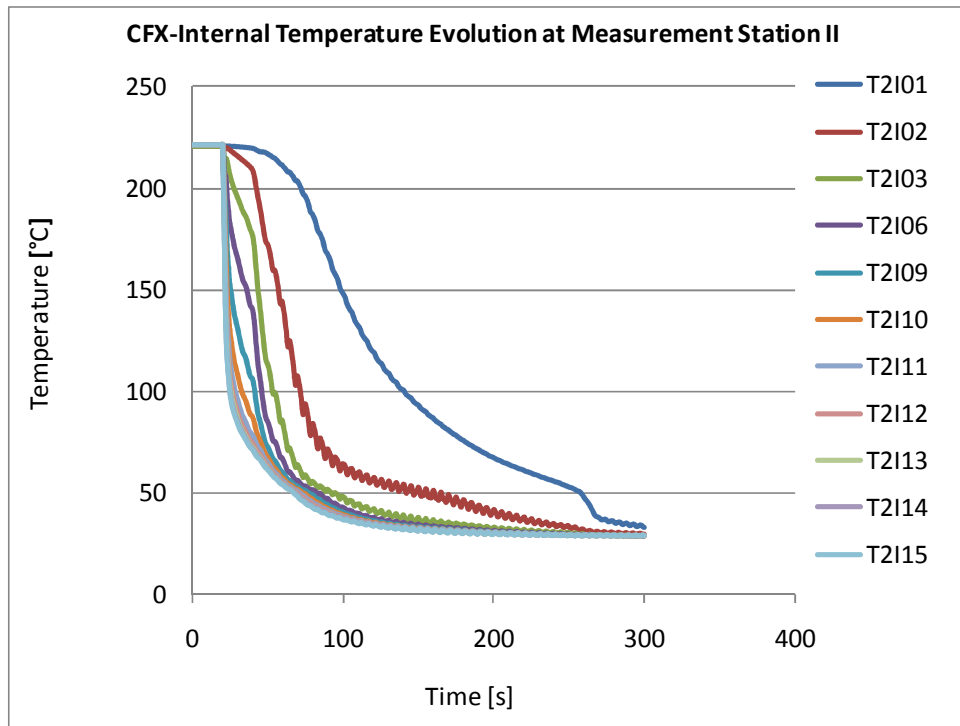

Figure 15 – Internal temperature – Station II

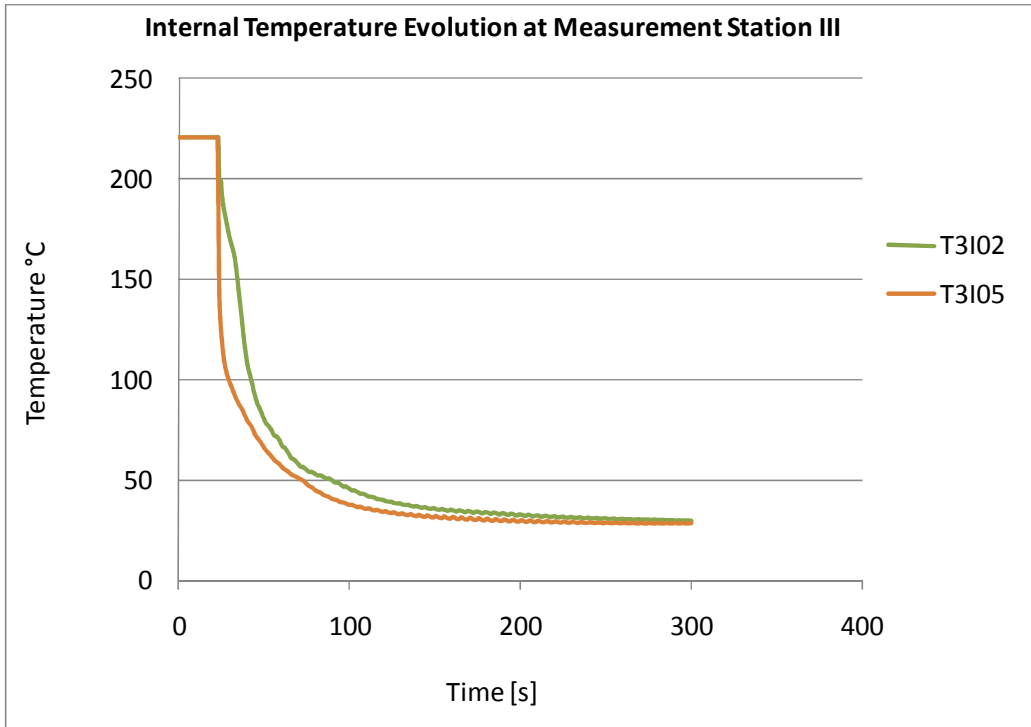

Figure 16 – Internal temperature – Station III

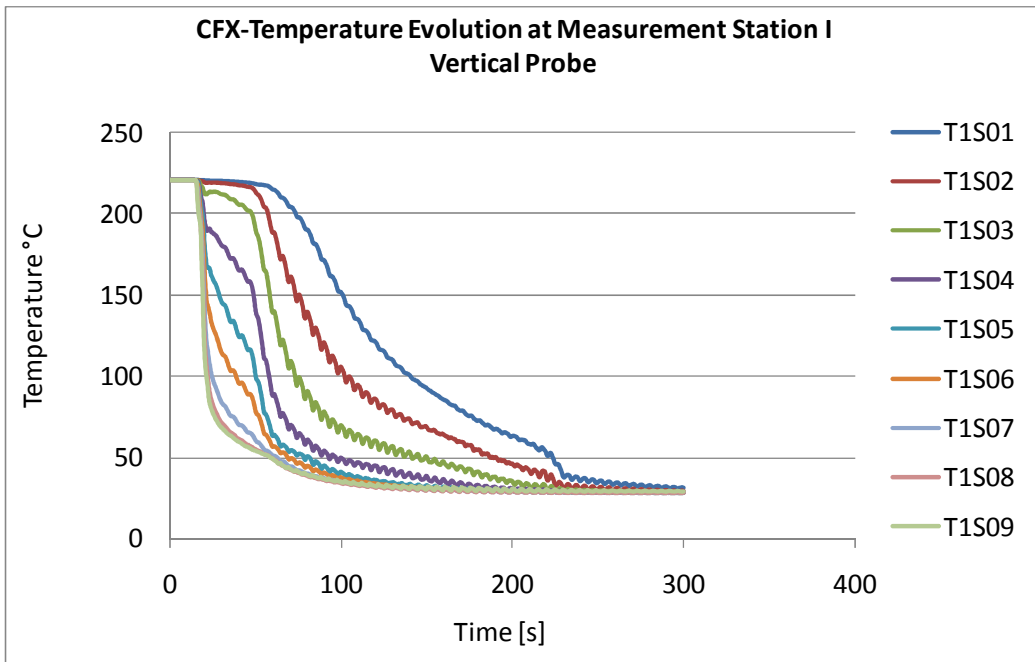

Figure 17 – Vertical probe temperature – Station I

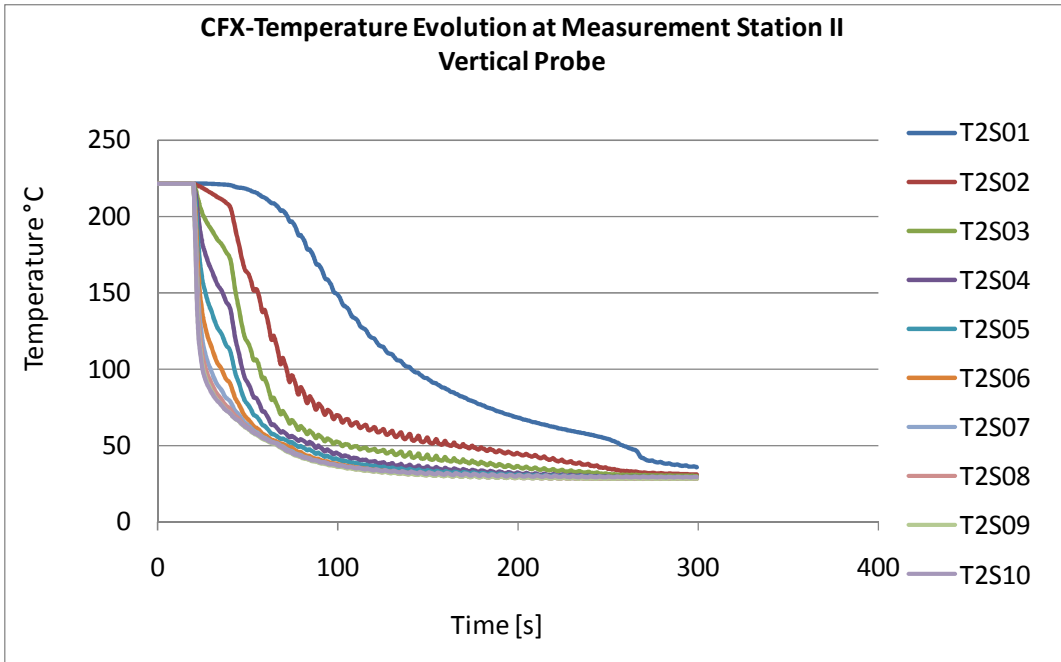

Figure 18 – Vertical probe temperature – Station II

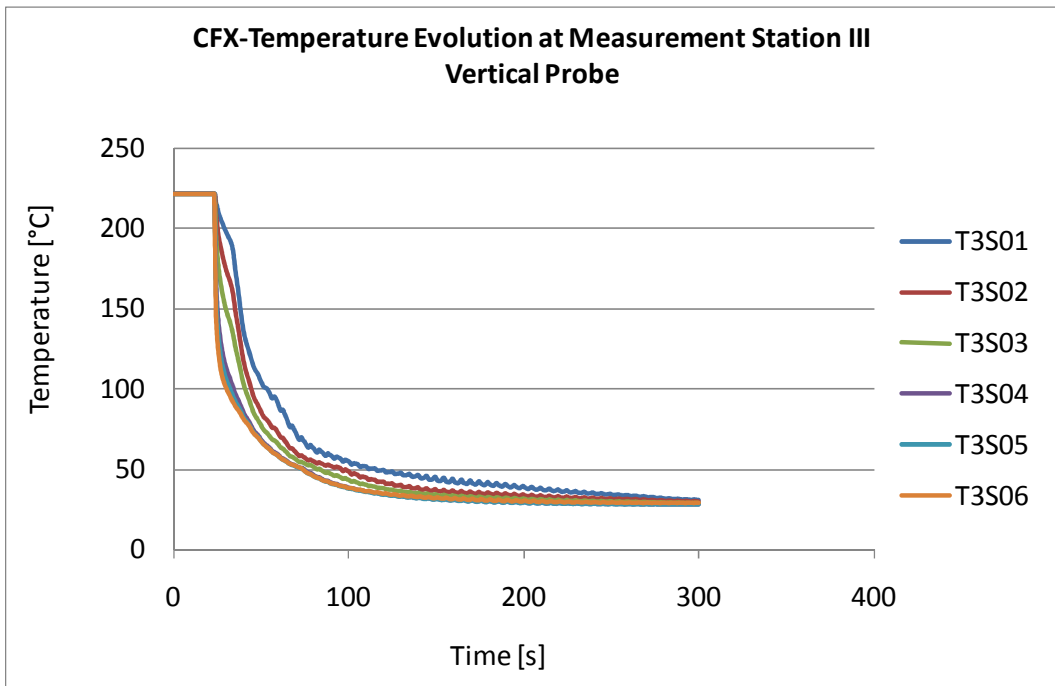

Figure 19 – Vertical probe temperature – Station III

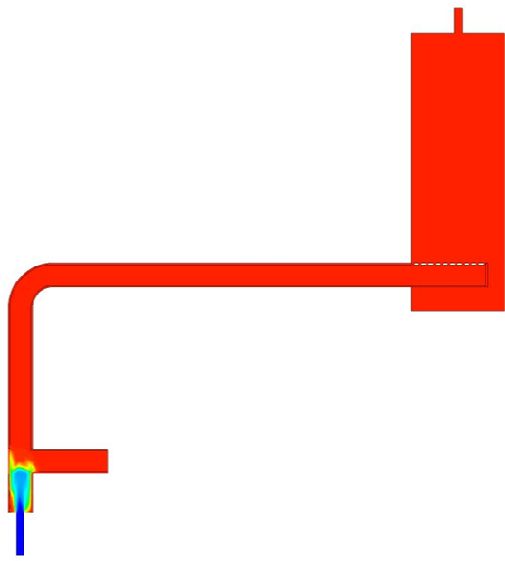

Figure 20 – Temperature contour – 2 s

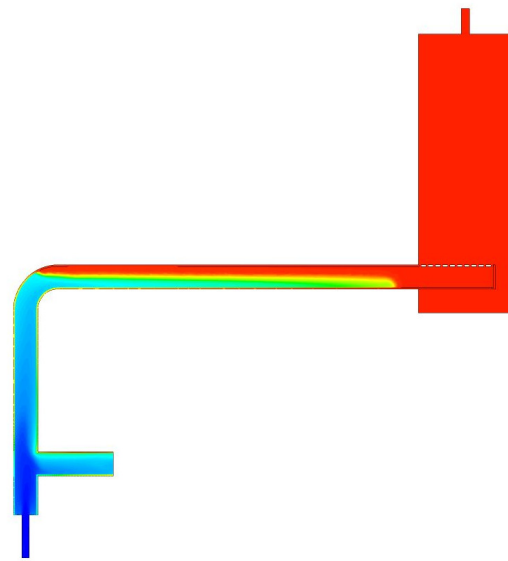

Figure 21 – Temperature contour – 25 s

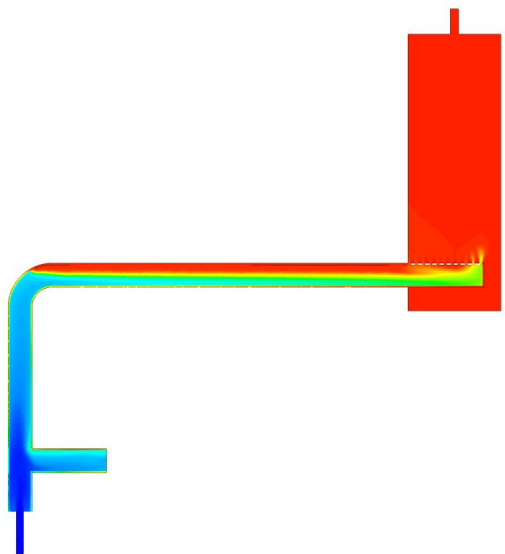

Figure 22 – Temperature contour – 28.5 s

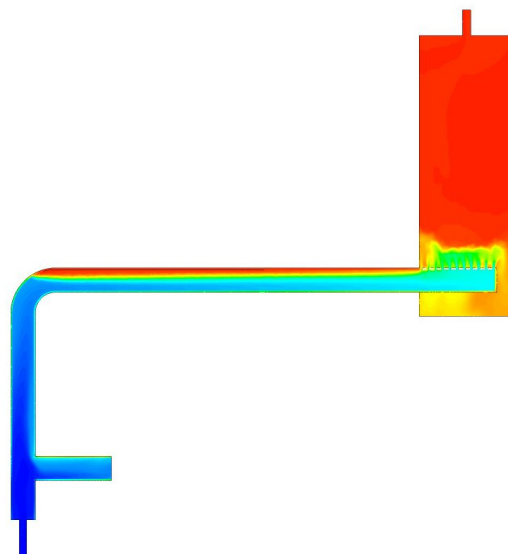

Figure 23 – Temperature contour – 50 s

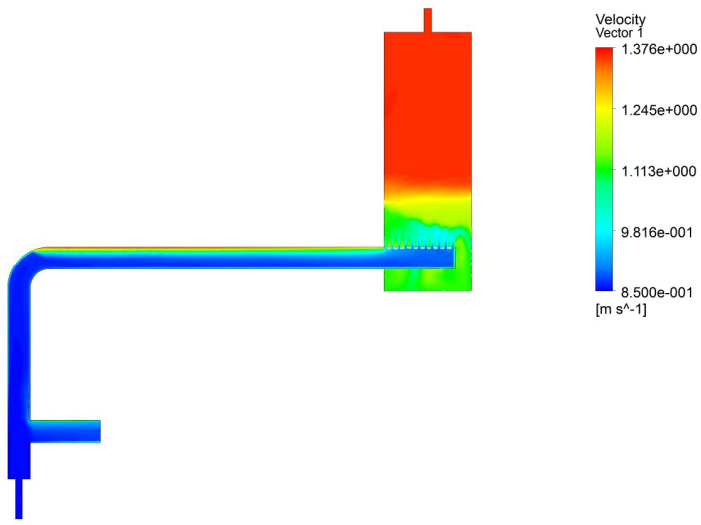

Figure 24 – Temperature contour – 100 s

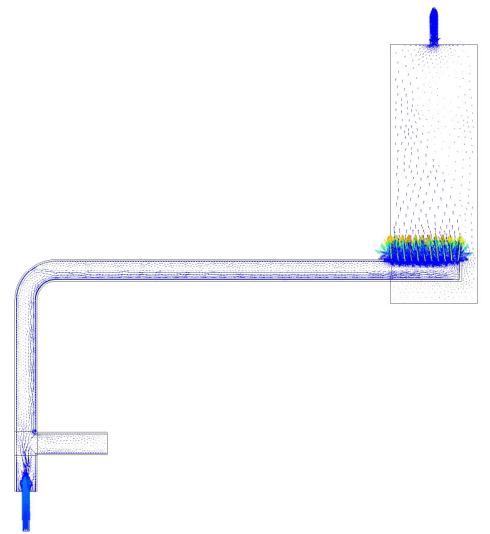

Figure 25 – velocity field in the region of the tube inside the steam generator vessel (injection nozzle) - 28.5 s

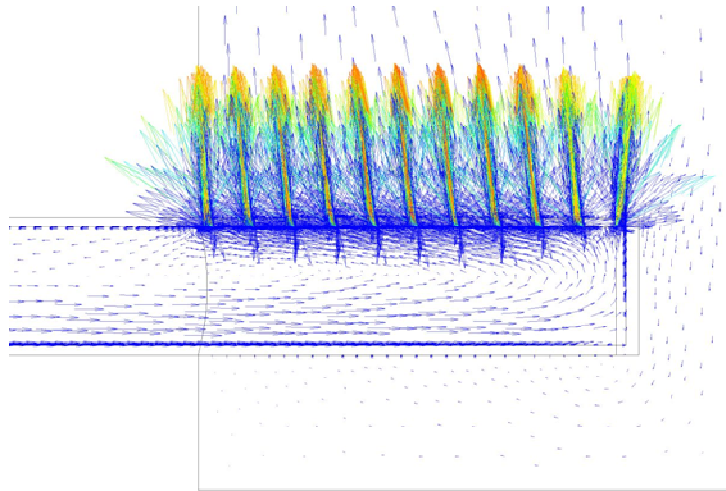

Figure 26 – velocity field detail in the region of the tube inside the steam generator vessel (injection nozzle) - 28.5 s

3. CONCLUSIONS

This CFD model, although with a simplified mesh, was able to simulate the stratification phenomenon. A more complex mesh was developed, however it was not used for the simulations due to the computational time. Results are presented in terms of wall temperature, internal temperature, vertical probe temperature, temperature contours and velocity fields.

REFERENCES

1. H. C. Rezende, A. A. C. Santos, M. A. Navarro, “Thermal Hydraulics special theme for CFD codes – Thermal stratification experiments”, Special Theme – INAC (2011).
2. ANSYS-CFX – 12.0, *User Manual*, ANSYS Inc., Canonsburg, Pennsylvania – United States (2009).
3. Maliska, C. R., *Transferência de Calor e Mecânica dos Fluidos Computacional*, LTC – Livros Técnicos e Científicos Editora S. A., Rio de Janeiro, RJ – Brasil (2004).
4. Anderson, John D., *Computational Fluid Dynamics – The Basics with Applications*, McGraw-Hill, New York, NY – United States (1995).
5. Launder, B.E. and Spalding, D. B., The Numerical Computation of Turbulent Flows, *Computer Methods in Applied Mechanics and Engineering*, Vol. 3, pp. 269-289 (1974)
6. Stern, F. et al., Comprehensive Approach to Verification and Validation of CFD Simulations-Part 1: Methodology and Procedures, *Journal of Fluids Engineering*, Vol. 123, pp. 793-802 (2001).
7. Wilson, R. V. et al., Comprehensive Approach to Verification and Validation of CFD Simulations - Part 2: Application for Rans Simulation of a Cargo/Container Ship, *Journal of Fluids Engineering*, Vol. 123, pp. 803-809 (2001).