

PERFORMANCE OF THALLIUM BROMIDE SEMICONDUCTOR DETECTORS PRODUCED BY REPEATED BRIDGMAN METHOD

Robinson Alves dos Santos¹, Fábio Eduardo da Costa, João Francisco Trencher Martins and Margarida M. Hamada²

Instituto de Pesquisas Energéticas e Nucleares, IPEN - CNEN/SP
Av. Professor Lineu Prestes 2242
05508-000 São Paulo, SP

¹rasantos@ipen.br ²mmhamada@ipen.br

ABSTRACT

TlBr crystals have been grown by the Repeated Bridgman method from commercial TlBr materials and characterized to be used as radiation detectors. We have shown that the Repeated Bridgman is effective to reduce the concentration of impurities in TlBr. It was observed that detectors fabricated from higher purity crystal exhibit significant improvement in performance compared to those produced from low purity crystals. However, problems still exist in TlBr detectors, due to the low charge carrier collection efficiency, which is probably caused by additional impurities or defects incorporated during crystal growth and detector fabrication processes.

1. INTRODUCTION

Over the past decade, compound semiconductors have attracted considerable attention as possible alternatives to Si and Ge for charge particle and photon detection [1,2]. The application of these detectors has been somewhat restricted, since Ge detectors provide high-resolution capabilities only at cryogenic temperatures (77K), because of their low resistivity at room temperature, and Si detectors exhibit less than 20% detection efficiency for gamma rays for energies above 35 keV because of their low photon absorption coefficient from these values [3]. Thus, there has been a great interest in developing semiconductors that have high photon absorption coefficient and can operate at room temperature, without sacrificing the advantages of Ge and Si detectors. The main physical semiconductor properties required for the fabrication of room temperature semiconductor detectors are: (1) high atomic number; (2) density for high absorption coefficient; (3) a band gap large enough to keep leakage currents low at room temperature and (4) large electron and hole mobility-lifetime products for efficient charge collection [2,4,5]. High-Z compound semiconductors such as CdTe, Cd_{1-x}Zn_xTe (CZT), HgI₂, PbI₂ and TlBr have been investigated as prospective materials for nuclear radiation detectors feasible to operate at room temperature.

TlBr has emerged among these types of detectors as a particularly interesting one due to its wide band gap (2.68 eV) and large density (7.5 g/cm³), high atomic number elements ($Z_{\text{Ti}}=81$ and $Z_{\text{Br}}=35$) and high resistivity ($>10^{10}$ Ωcm) [1,4,6]. In fact, TlBr detectors have been the subject of many investigations owing to some specific technological features and their good response to X and γ-rays, at room temperature. The performance of radiation detectors is controlled by both intrinsic and extrinsic factors. Carrier lifetime, mobility and the atomic number of the material used for radiation detectors represent intrinsic parameters,

while extrinsic factors, such as crystallographic perfection and impurity levels, may also, play a major role in the performance of these detectors [1,2,7].

Furthermore, crystal cutting, surface polishing and subsequent etching are, equally, important processes during the manufacturing of room temperature semiconductor radiation detectors, such as TlBr, CZT and HgI₂. Both mechanical polishing and chemical etching may affect the surface leakage. The centers resulting from mechanical polishing may both enhance the carrier recombination on the surface, by increasing surface trapping sites, and affect the surface leakage current, by providing more conductive pathways and altered electrical-field distributions. In some circumstances, the polarization effects can be introduced by surface processing and, effectively, removed by appropriate polishing and chemical etching [4,7].

The use of TlBr detector has been limited due to a polarization effect, possibly attributed to ionic conduction [8,9], which reduces the long-term stability. Efforts to investigate the polarization effects and long-term stability of the TlBr crystal detector were observed in the literature [6,10-13]. The phenomena produce a gradual charge trapping that reduces the charge collection, characterized by a pulse height decrease and bias detector current reduction, as time passes.

In this work, TlBr crystals have been grown and purified by the Repeated Bridgman method from commercial TlBr materials and prepared as radiation detectors. Their radiation responses were evaluated as a function of the crystal repeated growth number.

2. EXPERIMENTAL PROCEDURE

The commercially available TlBr powders (Merck), with nominal purity of 99.9%, was used as the starting material for growing crystals intended for detector applications. TlBr crystal was grown by the vertical Bridgman technique, using a quartz crucible in vacuum. To reduce impurities, this material was purified by Bridgman method. Preliminary, the crucibles were submitted to a rigorous chemical treatment and, subsequent thermal treatment, to avoid the adherence of the crystals in the tubes walls used in the melting. Afterward, the TlBr powder was introduced into a treated 50 cm long quartz tube of 20 mm diameter, evacuated to 10⁻⁶ Torr and sealed off. The crucible with TlBr was mounted into the vertical Bridgman furnace and the TlBr was melted at temperature of 550°C. A crystal, around 20 mm diameter and 30 mm long, was obtained with a growth rate of 1 mm/h. The crystal was sliced in wafers, cut transversally to direction (110), using a diamond saw and lubricated with glycerine during the cut. From this first growth, two slices of TlBr crystal were cut to be prepared as detectors.

After that, the remaining crystal was re-grown by the vertical Bridgman technique, in order to purify. Then, more two slices were cut from this crystal and prepared as detectors, by the same procedure used for the crystal obtained with one growth. The third growth was carried out using the remaining crystal and again, two more slices were prepared as detectors. The final thickness of the crystals was about 0.65 mm.

The crystalline quality and structural characterization of the TlBr crystal were analyzed by X-ray diffraction (XRD). X-ray diffraction patterns were obtained in a Siemens (D5005) Diffractometer, using CuK α radiation (2θ ranging from 20° to 60°).

After each cutting, the TlBr slices surfaces were treated using the procedures that presented better results in our previous studies [6,14]. In those works, better results were obtained for TlBr samples without chemical etching, after polishing, and with electrodes made using colloidal carbon in organic solvent from Viatronix™. Therefore, this procedure was used to prepare the TlBr surfaces. Fig. 1 shows a schematic diagram of the detector and its connection to the preamplifier.

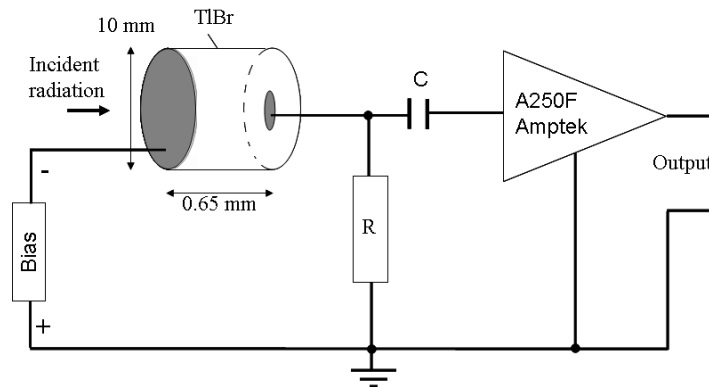

Fig. 1 – TlBr detector and preamplifier connection.

Fig. 2 shows the measurement schematic diagram. The experiments were carried with the detector set inside in a box with silica gel, at room temperature. The silica gel was used to prevent the humidity at the detector surface [6,15]. The output from A250F charge sensitive preamplifier was connected to a 450 EG&G Ortec Research Amplifier and to 918A EG&G Ortec Multichannel Analyzer, to obtain the pulse height spectra. The bias was supplied from 459 EG&G Ortec Bias Supply and the current measurements for obtaining the crystals resistivity, with the 619 Keithley Electrometer. ^{241}Am (59.5 keV, 401 kBq) and ^{133}Ba (81 keV, 175 kBq) radioactive sources were used for the measurements.

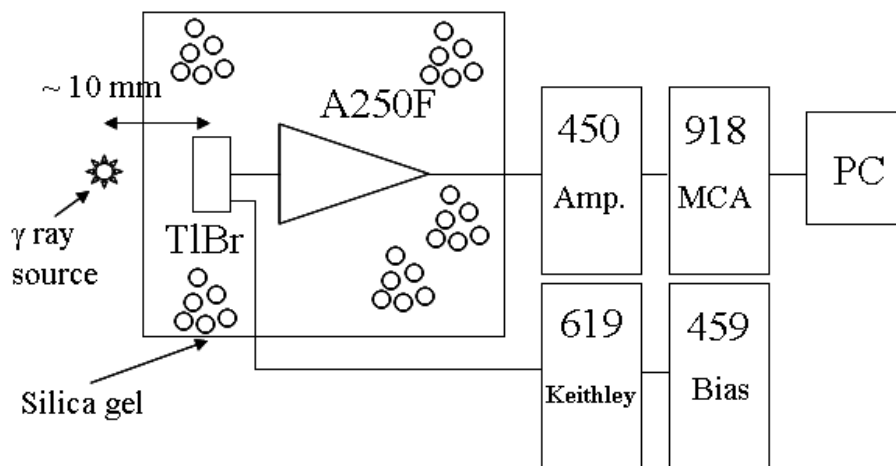

Fig. 2 – Schematic diagram for the measurements of a TlBr detector.

3. RESULTS AND DISCUSSION

Fig. 3 shows the TlBr crystals grown by the Repeated Bridgman method, once, twice and three times and the quartz crucible with TlBr salt used as a raw material for the growth, only as an illustration. As it can be observed in this figure, the crystal grown only once by the Bridgman method (3a) presented a darker color, being more accentuated in the upper section. The crystal grown by the Repeated Bridgman method twice (3b) and three times (3c) presented a bright yellow color and was uniform along the whole length. It could be, also, observed that the crystal grown three times, by the Repeated Bridgman method, was visually more transparent.



(a)



(b)



(c)

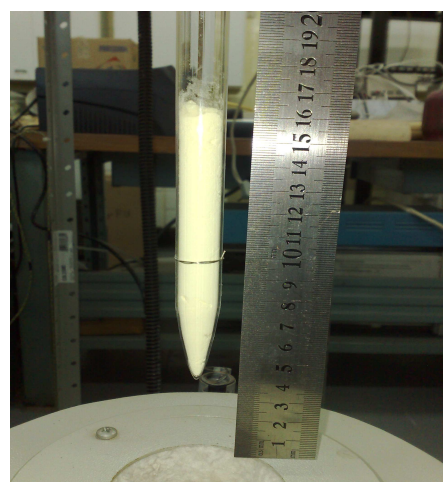

(d)

Figure 3 - Tl Br crystal grown only once (a); twice (b) and three times (c) by the Bridgman method. A quartz tube with TlBr salt was used as raw material (d).

Fig. 4 shows the X-ray diffraction pattern of TlBr powder and for the first and second growth, exhibiting yet, a complete set of reflections, respectively. No significant difference was observed in the diffractograms between the crystal without purification (a) and that purified twice, by the Repeated Bridgman (b). The result shows that the crystals have a similar structure to the cubic crystalline pattern of the TlBr (a). The diffractogram (b and c) indicates that the crystal is, preferentially, oriented in the (110) direction. This result is in agreement with the literature [1,16].

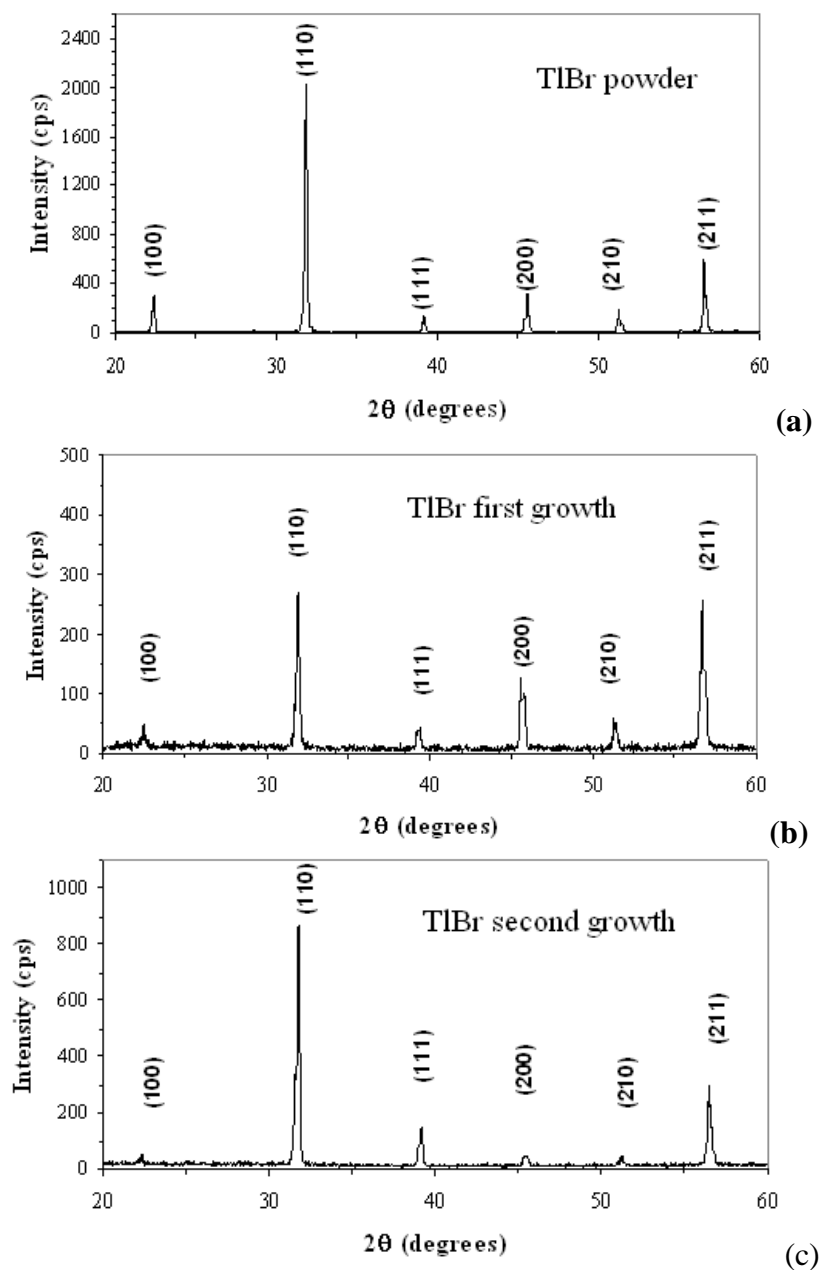

Figure 4- X-ray diffractogram of TlBr powder (a), first growth (b) and second growth (c).

Figs. 5 and 6 illustrate the pulse height spectrum obtained for the crystals grown twice and Figs. 7 and 8, for crystals grown three times, by the Repeated Bridgman. ^{241}Am and ^{133}Ba gamma sources were used for the crystal excitation. The bias used was 400 V and the spectrum counted for 3000 s.

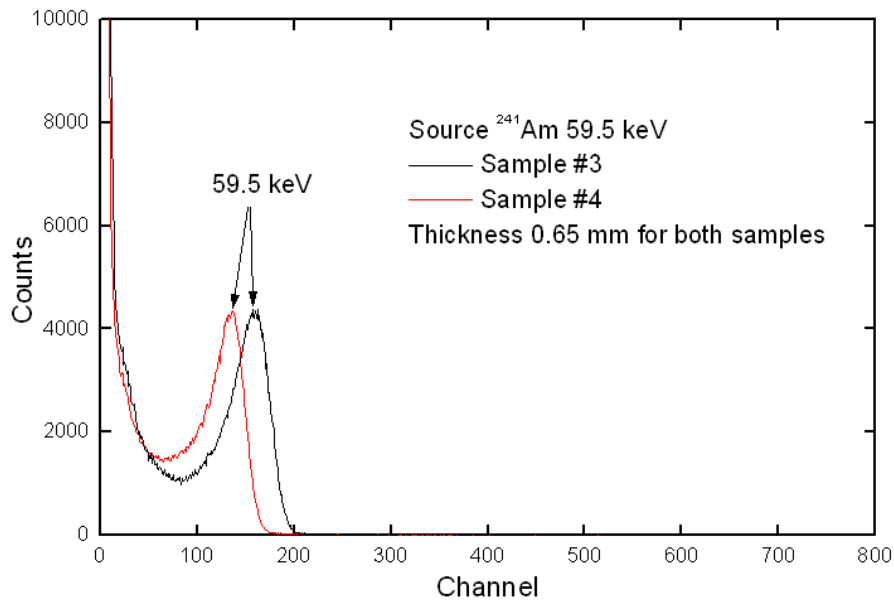

Figure 5 - TlBr detector energy spectrum with ^{241}Am excitation of the crystal grown twice, by the Repeated Bridgman method.

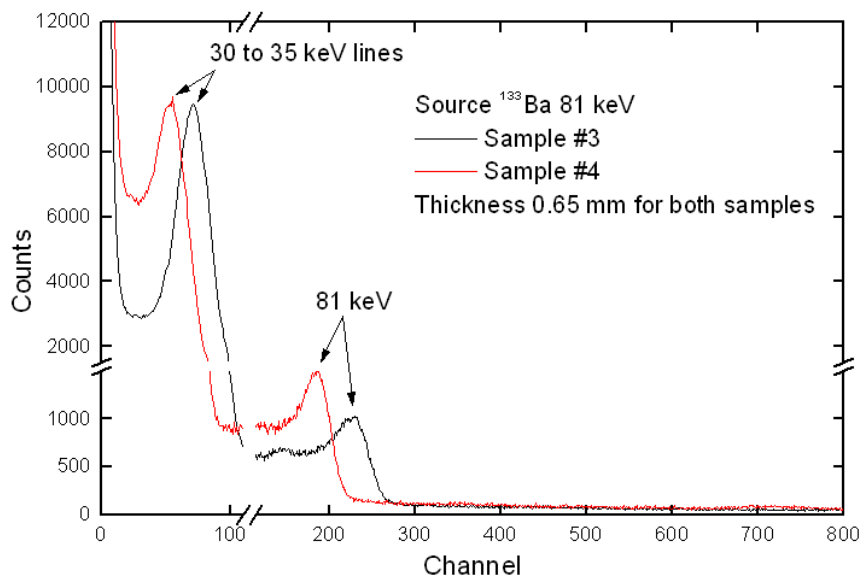

Figure 6 - TlBr detector energy spectrum with ^{133}Ba excitation of the crystal grown twice times, by the Repeated Bridgman method.

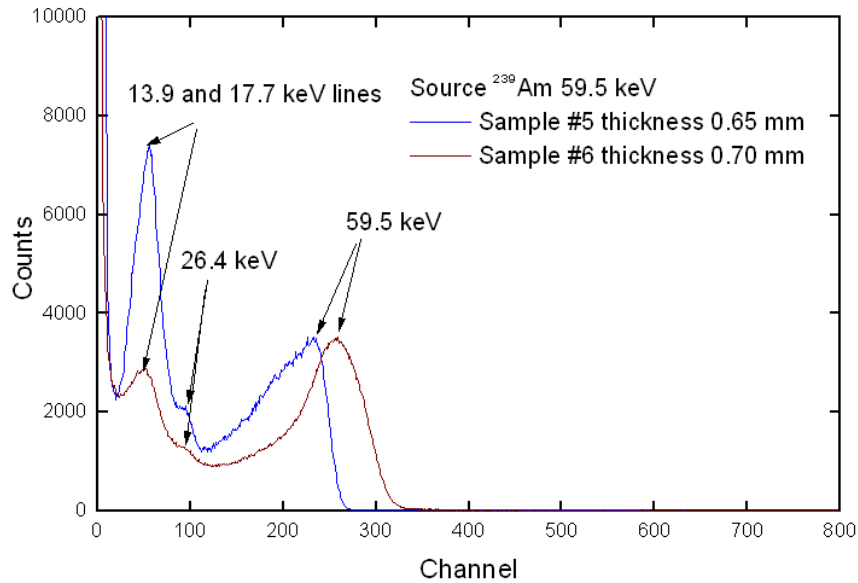

Figure 7 - TlBr detector energy spectrum with ^{241}Am excitation of the crystal grown three times, by the Repeated Bridgman method.

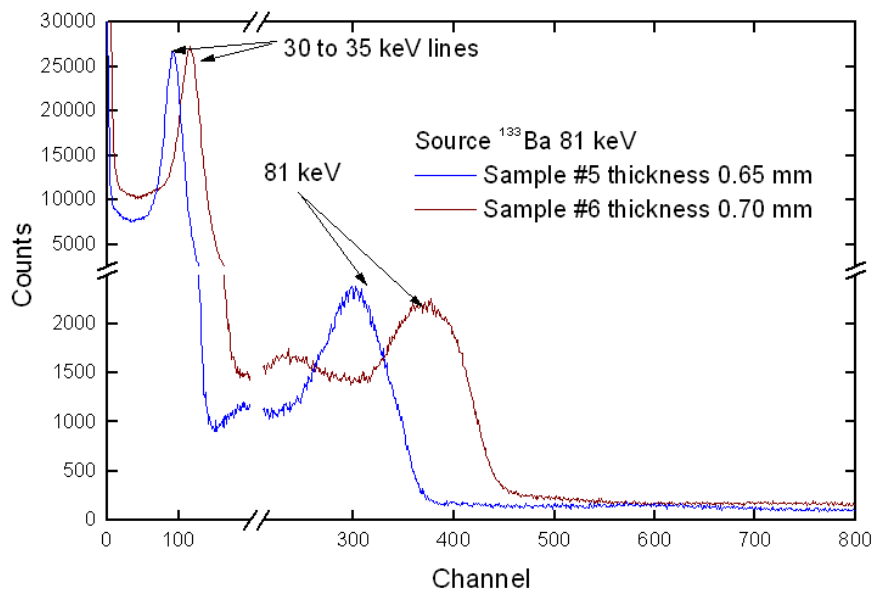

Figure 8 - TlBr detector energy spectrum with ^{133}Ba excitation of the crystal grown three times, by the Repeated Bridgman method.

For the TlBr crystal grown once, it was possible to observe the radiation response only in the current mode. For these detectors, the pulse mode was not observed due to a low radiation response and a high noise signal. At Fig. 6 and 8 can be seen just one photopeak from multiple X-ray lines between 30 and 35 keV and in Fig. 7 can be seen a photopeak from a multiple lines from ^{241}Am , but without resolution enough to observe each one separated.

Table 1 summarizes the results of the resistivity and energy resolution for the crystals produced in this work. The slices obtained from the crystal of the first growth, without purification, were denominated S1 and S2; the slices prepared from the crystal of the second growth were named S3 and S4; and those from the third growth, S5 and S6.

Table 1- Resistivity and Energy Resolution Values for the slices obtained from the crystals grown once, twice and three times, by the Repeated Bridgman method.

Growth	First		Second		Third	
Sample	S1	S2	S3	S4	S5	S6
Thickness (mm)	0.55	0.7	0.65	0.65	0.65	0.7
Resistivity ($10^{10} \Omega\text{cm}$)	0.46	1.8	5.7	3.8	5.2	8.3
Energy Resolution	No photo peak	No photo peak	28 keV 34% 59.5 keV 23% 81 keV 16%	28 keV 38% 59.5 keV 25% 81 keV 17%	28 keV 38% 59.5 keV 35% 81 keV 22%	28 keV 27% 59.5 keV 35% 81 keV 18%
Pulse height (channels)			28 keV (71) 59.5 keV (161) 81 keV (227)	28 keV (50) 59.5 keV (135) 81 keV (186)	28 keV (109) 59.5 keV (233) 81 keV (322)	28 keV (116) 59.5 keV (255) 81 keV (376)

No significant difference was observed in the resistivity and energy resolution values of the crystal re-grown twice and third times, but the pulse height was improved in the third growth due better charge collection and allowing observe the low energies lines from ^{241}Am (Fig. 9). These detectors showed good performance as nuclear radiation detectors, at room temperature. However, to obtain a better resolution is necessary to improve the charge collection [17]; to aim this goal, more purification should be carried out in order to reduce the impurities and reduce the charge traps. Further studies should be made to evaluate the influence of the crystals impurities in the detector performance. For this, crystals should be grown more times by the Repeated Bridgman method and the impurities reduction, after each re-growth, should be determined.

The polarization is still a factor that has limited the TlBr crystal use [11]. This phenomenon is described in the literature [11] as a gradual reduction of the detector bias current and a progressive pulse height reduction along the time. In this work, the reduction in the pulse height values was not observed for a continuous measurement period of 8-10 hours. For the samples from the third growth, it was observed that, after some hours without biasing, the initial bias current detector always returns to the initial condition. This result can be explained due to the better crystal structure that allows charges de-trapping without bias application. The detectors from the third growth have been used for three months, in this condition, without showing pulse height reduction. Further studies should be performed to understand this phenomenon better.

4. CONCLUSION

Concluding, the TlBr crystal purification and growth by the Repeated Bridgman method showed to be efficient to improve its performance as a radiation detector. A significant improvement in the characteristics of the detector-crystal was achieved, when the starting materials became purer. The resistivity and pulse height spectrum were sensitive parameters to evaluate the detector quality in function of the crystal growth number, by the Repeated

Bridgman method. The higher pulse height obtained in third growth can assure the methodology and indicates that the process reduced the charge traps improving the charge collection.

ACKNOWLEDGMENTS

The authors are grateful to Prof. Nelson Batista de Lima from CCTM/IPEN-CNEN-SP for measurements of X-ray diffraction. Robinson Alves dos Santos would like thanking CNPQ for the financial support of his scientific initiation fellowship.

REFERENCES

1. MCGREGOR, D.S.; HERMON, H. "Room-temperature compound semiconductor radiation detectors", *Nucl. Instr. and Meth. Phys. Res. A*, **Vol. 395**, p.101-124, 1997.
2. I.B. Oliveira, F.E. Costa, J.F.D. Chubaci, M.M Hamada, "Purification and preparation of TlBr crystals for room temperature radiation detector applications," *IEEE. Trans. Nucl. Sci.*, **Vol. 51**, pp. 1224-1228, June 2004.
3. "Si-PIN X-Ray Detector with 149 eV Resolution". <http://www.amptek.com> (2009)
4. A. Owens, M. Bavdaz, G. Brammertz, V. Gostilo, H. Graafsma, A. Kozorezov, M. Krumrey, I. Lisjutin, A. Peacock, A. Puig, H. Sipila, S. Zatoloka, "Hard X-ray spectroscopy using a small-format TlBr array," *Nucl. Instr. Meth. Phys. Res. A*, **Vol. 497**, pp.359-369, 2003.
5. Owens, M. Bavdaz, G. Brammertz, V. Gostilo, H. Graafsma, A. Kozorezov, M. Krumrey, I. Lisjutin, A. Peacock, A. Puig, H. Sipila, S. Zatoloka, "On the development of compound semiconductor thallium bromide detectors for astrophysics" *Nucl. Instr. Methods Phys. Res. A*, **Vol. 458**, pp.413-417, 2001.
6. F. E. Costa, C. L. Vieira, M. M. Hamada, "The Long Term Stability of the TlBr Detector Using Guard Ring and Without Surface Etching Treatment". *SORMA West*, Jun. 2008.
7. Oliveira, I.B. Costa, F.E. Kiyohara, P.K. Hamada, M.M." Influence of crystalline surface quality on TlBr radiation detector performance." *IEEE Trans. Nucl. Sci.*, **Vol. 52**, pp. 2058-2062, 2005.
8. J. Vaitkus, V. Gostilo, R. Jasinskaite, A. Mekys, A. Owens, S. Zatoloka, A. Zindulis, "Investigation of degradation of electrical and photoelectrical properties in TlBr crystals." *Nucl. Instr. And Meth. A*, **Vol. 531**, no. 1-2, pp.192-196, Jul. 2004.
9. V. Koslov, M. Kemell, M. Vehkamäki, and M. Leskelä, "Degradation effects in TlBr single crystals under prolonged bias voltage", *Nucl. Instr. And Meth. A*, **Vol. 576**, no. 1, pp.10-14, Jun. 2007.
10. T. Onodera, K. Hitomi, T. Shoji, "Spectroscopic performance and long-term stability of thallium bromide radiation detectors", *Nucl. Instr. And Meth. A*, **Vol. 568**, no. 1, pp. 433-436, Nov. 2006.
11. K. Hitomi, T. Shoji, Niizeki, Y. "A method for suppressing polarization phenomena in TlBr detectors" *Nucl. Instr. And Meth. A*, **Vol. 585**, no. 1-2, pp.102-104, Jan. 2008.
12. K. Hitomi., T. Onodera, T. Shoji, Z. He. "Pixellated TlBr detectors with the depth sensing technique", *Nucl. Instr. And Meth. A*, **Vol. 578**, no. 1, pp. 235-238, Jul. 2007.
13. K. Hitomi, Y. Kikuchi, T. Shoji, K. Ishii "Polarization Phenomena in TlBr Detectors." *2008 IEEE Nuclear Science Symposium Conference Record*, pp. 181-184, Oct. 2008.
14. C. L. Vieira, F. E. Costa, M.M. Hamada, "Effect of etching on the TlBr crystal surface and its radiation response", *International Nuclear Atlantic Conference, VIII ENAN*, Santos, Brazil, Sep. 2007.

15. F. E. Costa, C. H. Mesquita, M. M. Hamada, "Temperature Dependence in the Long-Term Stability of the TlBr Detector" *IEEE Trans. Nucl. Sci.*, **Vol. 56**, pp. 1-6, 2009.
16. K. Hitomi, M. Matsumoto, O. Muroi, T. Shoji, and Y. Hiratate, "Characterization of thallium bromide crystals for radiation detectors applications," *J. Crystal Growth*, **Vol. 225**, pp.129-133, 2001.
17. K. Hitomi, T. Murayama, T. Soji, T. Suehiro, Y. Hiratate " Improved spectrometric characteristics of thallium bromide nuclear radiation detectors" *Nucl. Instr. And Meth. A*, **Vol. 428**, pp. 372-378, 1999.