

Development of a mini-extrapolation chamber for calibration of $^{90}\text{Sr}+^{90}\text{Y}$ sources

Mércia L. Oliveira and Linda V.E. Caldas
Instituto de Pesquisas Energéticas e Nucleares
Comissão Nacional de Energia Nuclear
Av. Prof. Lineu Prestes, 2242, 05508-000, São Paulo, SP, Brazil
E-mail: mlolivei@ipen.br; lcaldas@ipen.br

Abstract. $^{90}\text{Sr}+^{90}\text{Y}$ applicators are commonly utilized in the brachytherapy, including ophthalmic procedures. The recommended instruments for the calibration of these applicators are the extrapolation chambers, ionization chambers that allow the variation of their sensitive volume. Using the extrapolation method, the absorbed dose rate at the applicator surface can be determined. The aim of the present work was to develop a mini-extrapolation chamber for the calibration of $^{90}\text{Sr}+^{90}\text{Y}$ beta ray applicators. The developed mini-chamber has 3.0 cm of outer diameter and 9.6 cm of length. An aluminized polyester foil is used as the entrance window while the collecting electrode is made of graphited polymethylmethacrylate. This mini-chamber was tested in $^{90}\text{Sr}+^{90}\text{Y}$ radiation beams from a plane ophthalmic applicator, showing adequate results.

1. Introduction

Beta radiation sources are widely utilized in brachytherapy, including ophthalmic, dermatological, intracranial and intravascular procedures. Because of the low penetration of the beta particles in matter, sources of $^{90}\text{Sr}+^{90}\text{Y}$ are utilized in the treatment of superficial lesions of eyes and skin. Since the 50's, $^{90}\text{Sr}+^{90}\text{Y}$ sources have been utilized in the postoperative treatment of pterygia, fibrovascular proliferative tissues that can cover the cornea, causing visual disturbances, and may result in blindness [1]. Strontium-90 decays to yttrium-90; these two isotopes are in equilibrium because of the difference between their half-lives. The applicators used in brachytherapy consist of silver cups, plane or concave, containing the radioisotopes incorporated onto them. The silver cup has a face filter for low energy beta particles emitted by ^{90}Sr , so the emitted spectrum resembles pure ^{90}Y . Plane sources are typically about 10-12 mm in diameter while concave sources range from 9 to 23 mm in diameter and 10 or 15 mm of radius of curvature. The applicators have a special plastic shield to protect the operator. Usually the total dose to be delivered to the surface is fractionated in several radiation therapy sessions, that last less than one minute; during the session, the applicator is put manually in contact with the area where the pterygium was removed from [2].

The recommended instruments for the calibration of these applicators are special ionization chambers, the extrapolation chambers. These chambers allow the variation of their sensitive volume by means of a micrometric screw. The distance between the collecting electrodes, and consequently the air volume inside the chamber, should be sufficiently small to not disturb the beta particle flux, satisfying the Bragg-Gray conditions. The ionization current produced is measured as a function of the distance between the collecting electrodes and, by extrapolating this function to null distance, it is possible to determine the absorbed dose rate at the chamber surface [2-4].

The applicators should be specified in terms of the reference absorbed dose rate to water at a reference point (1 mm from the source surface, along its axis of symmetry). The materials constituting the chamber should be water equivalent, as polymethylmethacrylate and carbon, to simulate appropriately the transmission and backscattering properties of the beta particles in water. For clinical applications, the source uniformity and the dose distribution shall be provided as additional specifications for these sources [2-4].

An extrapolation chamber was developed at IPEN for beta ray protection level measurements and for use in low-energy X radiation standard beams [5-6]. The aim of the present work was to develop a mini-extrapolation chamber for the calibration of $^{90}\text{Sr}+^{90}\text{Y}$ beta ray applicators.

2. Materials and Methods

The developed mini-extrapolation chamber is described in details in the next section. In this section, the tests performed with the chamber will be presented.

For the short and medium term stability tests, a ^{90}Sr check source (nominal activity of 33.3 MBq, 1988), PTW, type 8921, was utilized. A special polymethylmethacrylate (acrylic) cap was designed to allow a reproducible positioning of the source and the chamber. This cap, shown in Fig. 1, was utilized to protect the chamber entrance window too.

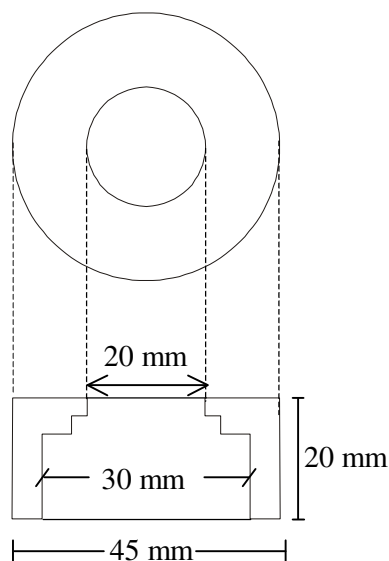

FIG. 1. *Special acrylic cap for use at the short- and medium-term stability tests.*

The leakage current was estimated before and after each measurement series. In the first case, the charge was collected during 20 min without using any radiation source. To determine the leakage current after irradiation, the same ^{90}Sr check source was used to measure the charge collection during 2 min. Then, the source was removed and the subsequent charge value was measured during 20 min.

A plane $^{90}\text{Sr}+^{90}\text{Y}$ applicator was utilized to obtain extrapolation curves. During these measurements, the distance between the chamber entrance window and the applicator surface was 1 mm and the chamber depth was changed between 0.4 and 1.0 mm. The polarizing voltage applied to the chamber was 50 V in all measurements.

The ionization currents were measured using a PTW electrometer, model UNIDOS 10001. All measurements were corrected to the reference conditions of temperature and pressure (20°C and 101.3 kPa).

3. Results and Discussion

3.1. Mini-extrapolation chamber

The developed mini-extrapolation chamber is shown in Fig. 2. This chamber has an aluminum body with a micrometric screw coupled to it, that allows to vary the chamber depth with an uncertainty of less than 10 μm . The entrance window is made of aluminized polyester; an acrylic ring is used to stretch it. A polarizing voltage is applied to the chamber body; therefore the entrance

window is polarized. The collecting electrode is isolated from the body chamber; thus a voltage difference is established between the entrance window and the collecting electrode.

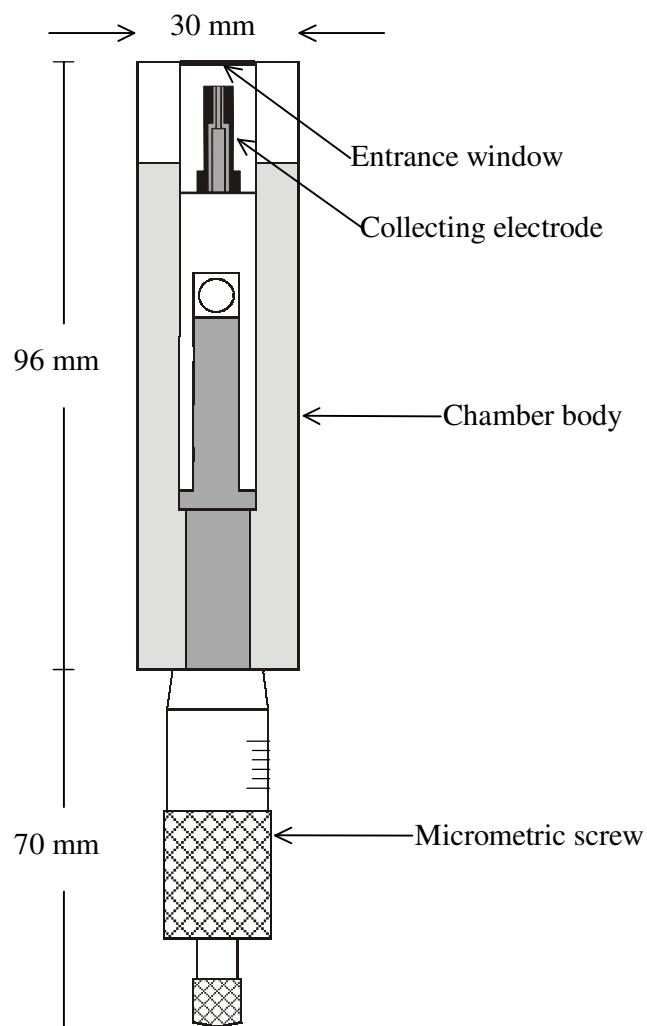

FIG. 2. *Mini-extrapolation chamber developed in this work.*

The collecting electrode is made of acrylic coated with graphite and surrounded by a Teflon insulating cap. A graphited guard ring surrounds the collecting electrode and the insulating cap. The effective area of the collecting electrode is 1.68 mm^2 .

3.2. *Leakage current*

The leakage currents measured before and after each irradiation were always less than 0.7% of the current measured with the check source for the same chamber depth (1.0 mm).

3.3. *Short- and medium-term stability tests*

For the short-term stability test (or repetitivity test) of the extrapolation chamber, ten successive measurements were taken using the check source and the special acrylic cap of Fig. 1, under

reproducible conditions. The variation on the chamber response was less than 0.39%. Taking measurements during 10 days, the medium-term stability test (or reproducibility test) showed very good results: a maximum variation of 0.81%. The results are shown in Fig. 3. These results are in accordance with the recommended limits [7].

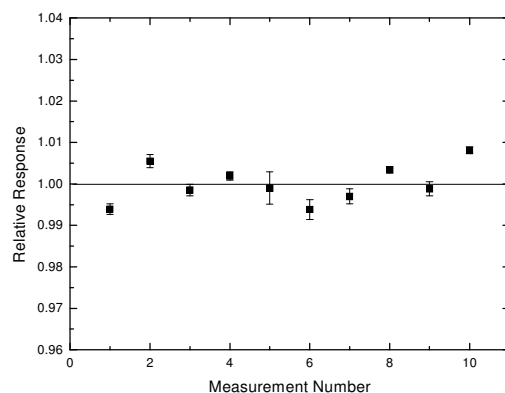

FIG. 3. *Medium-term stability test of the developed mini-extrapolation chamber.*

3.4. Extrapolation curves

Extrapolation curves were obtained by measuring the collected charge during 2 min for each chamber depth and voltage polarity. The mean values of the determined currents were plotted as a function of the chamber depth. The maximum standard deviation for these measurements was 0.40%. The results show a linear behavior for the variation of the measured current with the chamber depth, as expected (Fig. 4). The minimum correlation coefficient obtained was equal to 0.9997.

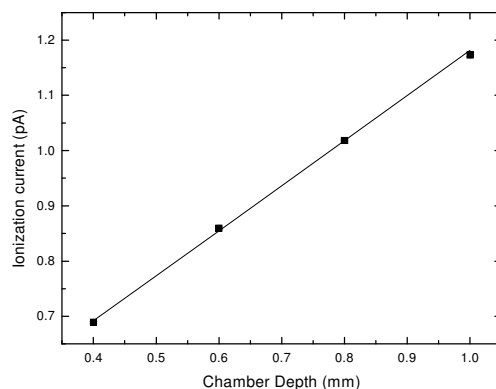

FIG. 4. *Extrapolation curve of the developed mini- extrapolation chamber.*

4. Conclusions

A mini-extrapolation chamber was developed for use as reference instrument for calibration of beta ray applicators at the Calibration Laboratory at IPEN. The preliminary results showed adequate performance when it was used for beta radiation detection of a $^{90}\text{Sr}+^{90}\text{Y}$ plane ophthalmic applicator.

5. Acknowledgments

The authors are thankful to Mr. M. Xavier for technical assistance, to Conselho Nacional de Desenvolvimento Científico e Tecnológico (CNPq) and to Fundação de Amparo à Pesquisa do Estado de São Paulo (FAPESP), Brazil, for partial financial support of this work.

6. References

1. Monteiro-Grillo, I., Gaspar, L., Monteiro-Grillo, M., Pires, F., Da Silva, J.M.R. *Postoperative irradiation of primary recurrent pterigium: results and sequelae*. Int. J. Radiat. Oncol. Biol. Phys., 48(3):865-869, (2000).
2. International Commission on Radiation units and Measurements. *Dosimetry of beta rays and low-energy photons for brachytherapy with sealed sources*. ICRU Draft Report, (2001).
3. Soares, C.G., Vynckier, S., Järvinen, H., Cross, W.G., Sipilä, P., Schaeken, B., Mourtada, F.A., Bass, G.A., Williams, T.B. *Dosimetry of beta ray ophthalmic applicators: comparison of different measurement methods*. Med. Phys., 28(7):1373-1384, (2001).
4. De Almeida, C., Dewerd, L., Järvinen, H. and Soares, C. *Guidelines for the calibration of low energy photon sources and beta-ray brachytherapy sources*. SSDL Newsletter, 43(1):4-25, (2000).
5. Dias, S.K., Caldas, L.V.E. *Extrapolation chamber response in low-energy x radiation standard beams*. J. Appl. Phys., 89(2):669-671, (2001).
6. Dias, S.K., Caldas, L.V.E. *Characteristics of an extrapolation chamber for beta-ray protection level measurements*. J. Appl. Phys., 86(1):671-673, (1999).
7. International Electrotechnical Commission. *Medical electrical equipment dosimeters with ionization chambers as used in radiotherapy*. IEC-731-82, (1982).