

# Application of DLC coating in cylinder liners for friction reduction

**Edney Rejowski**  
**Paulo Mordente**

MAHLE Brazil – São Paulo, Brazil

**Marina Pillis**

IPEN – São Paulo, Brazil

**Tom Casserly**

Sub One Technology, Inc. – Pleasanton, USA

Copyright © 2011 SAE International

## ABSTRACT

In the past decades, continuous improvement to the finishing process (honing) of cylinder liner has led to a considerable reduction in engine friction, wear and oil consumption via optimization of the running surface topography. However, in order to meet the constantly restrictive environmental regulations, the automotive industry has been invested a lot of efforts in reducing fuel consumption and exhaust emission to expressive low levels mainly by minimizing friction losses. The properties of Diamond-like carbon (DLC) coatings are well known to offer superior wear resistance and low friction making it suitable for many different tribological applications. This paper discusses the application of DLC in Heavy Duty Diesel (HDD) cylinder liners as an alternative to reduce friction on the power cell as well as its tribological performance when submitted against coated top piston rings with CrN. Reciprocating rig and fired engine tests are presented. Evaluation criteria for rig test included friction under lubricated condition at constant oil temperature of 120°C. Test results show that DLC coating improved tribological system decreasing friction losses by 19%. Finally, results from a short durability test on HDD engine platform have confirmed a significant reduction of 2.5% on specific fuel consumption as well as superior wear resistance of DLC coated cylinder liners when compared with base uncoated ones.

## INTRODUCTION

Approximately 40% of the energy consumed by Heavy Duty Diesel (HDD) engine is converted to useful work and up to 15% of the total energy is related to friction [1, 2]. A well accepted approach to increase the effective work on the Internal Combustion Engines (ICE) is to reduce the energy losses [1]. Although the specific friction share among the components depends on several factors, for instance, engine design and operation condition among others, it is accepted that a considerably friction contributor is related to the piston-cylinder systems, consequently those components are naturally selected for design optimization due to good potentials of friction reduction [2,3].

Piston and piston ring-pack are the two largest contributors to engine mechanical losses as detailed in the Figure 1. It is also known that changes in the cylinder bore topography are considered to be one of the variants to reduce friction losses [4,5].

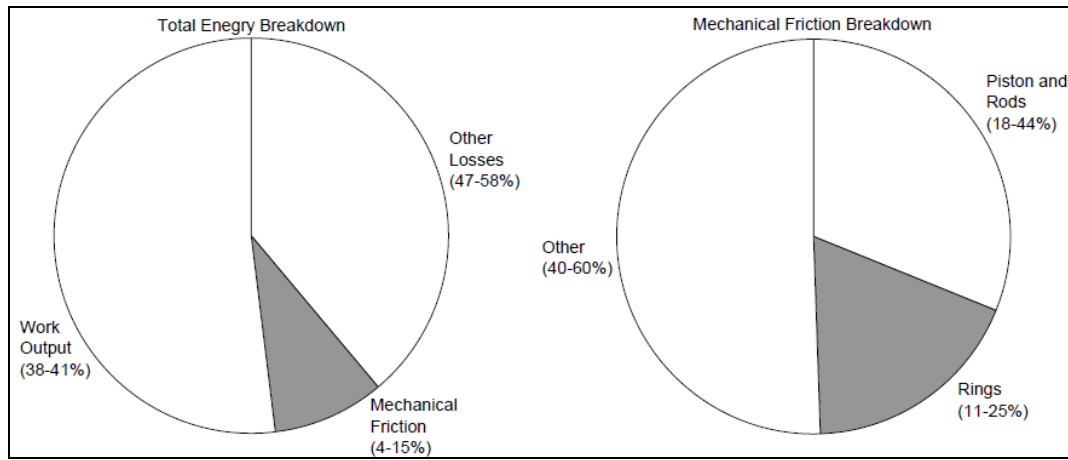

**Figure 1 – Breakdown of total energy usage and engine mechanical losses [2]**

Design optimization of the power cell components was and is still widely explored for reduction of mechanical losses on modern ICE. Another feasible approach for losses reduction is the application of low friction protective films on the components. A lot of effort has been made to develop anti-friction coatings for piston rings and piston skirts. However efforts to develop low friction coatings on the cylinder liner honed surface are rarely observed [4].

Taking into account low friction coatings several options would be promising however diamond like carbon (DLC) films are well recognized by their low friction, high wear resistance and chemical stability among some other positive features [6,7].

Most of the outstanding DLC properties are attributed to significant fractions of  $sp^3$  carbon bonds type, which provides attractive physical and mechanical properties that are, to a certain extent, similar to diamond. A wide variety of amorphous carbon materials can be classified as DLC, some containing up to about 50% atoms of hydrogen (a-C:H), and others containing less than 1% atoms of hydrogen (a-C) [7]. Consequently the right choice of DLC coating type is crucial for good balance between low friction and coating durability.

The design of modern engines has led to more demanding combustion pressures and consequently higher thermal and mechanical loads, making the working environment of the power cell components much more aggressive [6]. In that sense, the selection of the right coating plays a major role in the good performance of the component. In this study, some wet cylinder liners for HDD engine application received an inner DLC coating with a thickness of 3.5  $\mu\text{m}$ . That coating was applied by a Plasma Enhanced Chemical Vapor Deposition (PECVD) process and produced parts were evaluated against conventional uncoated pearlitic cast iron liners in regard to tribological aspects as well as specific fuel consumption behavior.

## DIAMONT-LIKE CARBON COATINGS

Diamond-like carbon (DLC) coatings have been extensively investigated during the last decades. DLC coatings have high hardness, low friction coefficients, excellent resistance to wear and sometimes low surface energies. They are deposited directly onto component surfaces under vacuum, using various chemical and physical vapor deposition methods [8,9,10].

Commonly a distinction is drawn between hydrogen free (a-C or ta-C) and hydrogen containing (a-C:H) films. Both types can be modified by incorporation of additional elements like metals (a-C:H:Me) or non-metallic elements (a-C:H:X-X: additional elements). Other properties of DLC based coatings which could be rather interesting for technical applications are: a broad range of electrical resistivity, transparency in the infrared spectral range, chemical inertness or variable wetting behavior (corresponding to different surface energies) [10].

Especially a-C:H and metal containing a-C:H:Me coatings are today established in industrial practice, mainly for automotive applications [9,10].

The combinations of excellent mechanical and tribological properties have been well known for several years. Low friction coefficients ( $\mu \leq 0.2$  against steel under dry, lubricant free conditions) were measured for a-C:H and also for metal- containing amorphous hydrogenated diamond-like carbon films (a-C:H:Me or Me-DLC). In the following discussion the abbreviations a-C:H and a-C:H:Me shall be used [10].

Very interesting and promising coatings properties can be achieved by modifying with non-metal elements: a-C:H: X (X: Si, O, F, N). Silicon containing a-C:H:Si film are known to have still lower friction coefficients than a-C:H [7,10]. Films containing both silicon and oxygen (a-C:H:Si:O) are characterized by rather low surface energies [11].

## PROCESSING OF DLC COATED LINERS

A hollow cathode plasma immersion ion processing (HCPIIP) deposition method was selected due to its ability to generate thick and hard DLC films in the inner diameter of metallic tubes. Figure 2 shows a schematic of the deposition system which uses a hollow cathode discharge (HCD) to generate extremely high density plasma which enables rapid growth of DLC based films, with good adhesion and low residual film stress. In this case, the cylinder liner itself is used as the vacuum and processing chamber as depicted in Figure 2. The critical process parameters for maintaining the desired discharge are the internal diameter of the part ( $d$ ) and the operating pressure ( $P$ ) with the product ( $P \cdot d$ ) being a critical parameter to enable the hollow cathode discharge [12].

The coating process starts by introducing cleaning, adhesion, and process gases into the entrance head as shown in Figure 2. The gas then travels from one end to the other where it is intensely ionized by the hollow cathode discharge. At the exit head, a vacuum pump and throttle valve are used to control operating pressure and to pump away any reaction by-products. The component is a critical element of the plasma electrical circuit, serving as the negatively biased cathode with respect to positively biased anodes, located at the entrance and exit heads. Insulating spacers are used to isolate electrically the anode from the cathode to be coated. The cathode bias plays an important role in improving the stress, density and adhesion of the films by increasing the ion bombardment energy. Under suitable vacuum conditions, an asymmetric pulsed DC waveform is used to maintain high density plasma inside the component. Energetic positive ion bombardment is controlled by the magnitude of the applied voltage to the component to be treated and by the chamber (part) pressure. Gas flow and pumping speed are varied such that the pressure inside the component provides a regime where a hollow cathode discharge can be maintained under the applied component voltage. This pressure is such that the electron mean free path is adjusted to the cylinder diameter, which causes high energy electrons to oscillate (pendulum motion) across the opposing cathode walls resulting in multiple ionizing collisions and two orders of magnitude higher ion-density than a standard discharge plasma [12,13].

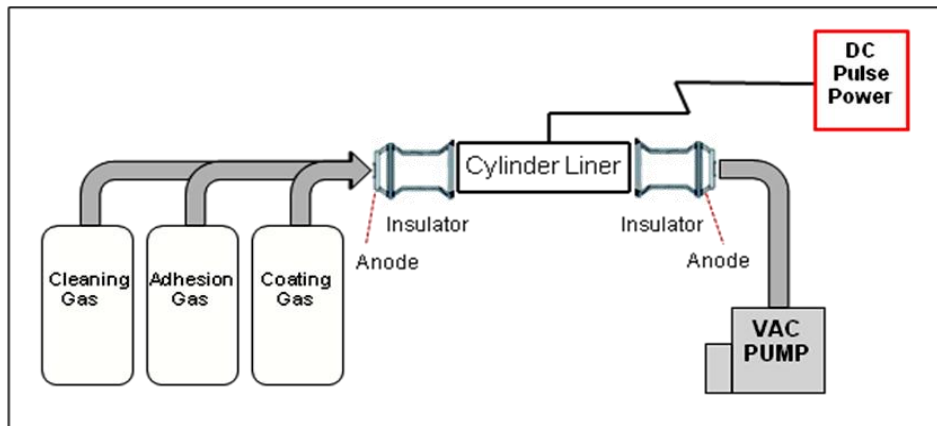

*Figure 2: HCPIIP system set up [12].*

Due to the insulative nature of DLC films, short microsecond pulses are used to dissipate any positive charge build up on the coating surface. This positive charge must be removed quickly for film deposition to continue. This charge is compensated when the plasma sheath collapses during the off cycle and particularly during the reverse portion of the waveform when a small positive bias is applied to the part. Adjusting the duty cycle of the DC waveform can allow good control of the film uniformity by allowing the gas to replenish during the off cycle within the cylinder. The use of the HCD provides many benefits including:

1. High deposition rate
2. Improved film properties, including reduced residual film stress due to intense ion bombardment energy allowing film growth above the usual PVD/PECVD processes
3. Thin conformal plasma sheath delivers consistent thickness and properties throughout the cylinder liner

## SPECIMENS AND CHARACTERIZATION

The DLC coating was deposited by the process described above on the whole internal diameter of HDD cylinder liners manufactured by conventional centrifugal casting process in alloyed gray cast iron with minimum ultimate tensile strength of 320MPa and hardness of 240HB. The Figure 3 shows a half liner piece with DLC coating over the entire honed surface.

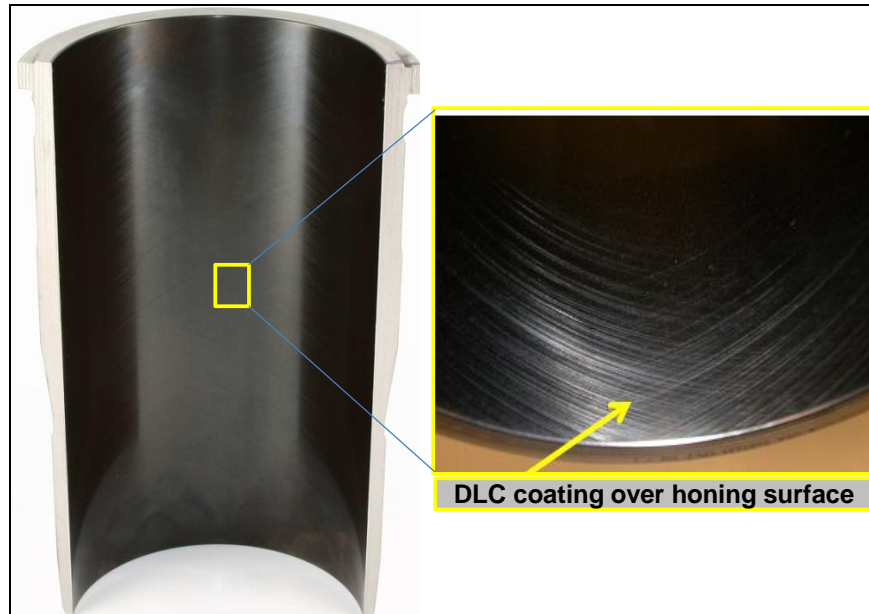

**Figure 3 – Detail of cylinder liner running surface after DLC deposition.**

Surface roughness measurement was performed before and after coating deposition. Parameters such as Ra (Arithmetic Average Roughness) that basically reflects the average height of roughness component irregularities from a main line, the Rz that measures the vertical distance from the highest peak to the lowest valley within five sampling lengths and represents the average of five values and the Rk family parameters that represent the Abbott-Firestone curve from a specific roughness length [14]. The 2D stylus roughness measure control was performed in accordance with ISO 13565-2 in order to evaluate the capability of HCPIIP process to maintain the original substrate honing characteristics. The roughness measure control was performed at two cylinder liner heights (30 and 90mm) from the top of the cylinder liner and in four different angular positions, 0°, 90°, 180° and 270°. The roughness parameters measured at 30 mm from the liner top is shown in the Table 1 and represents quite well the surface finishing also measured at 90 mm.

**Table 1 – Roughness control measured at 30 mm from top before and after DLC film deposition**

Roughness parameters		Ra	Rz	Rpk	Rk	Rvk	Mr1 (%)	Mr2 (%)	
Liner height @ angular position	30mm / 0°	Before	0.515	4.16	0.29	0.79	1.73	7.1	75
		After	0.637	4.71	0.25	0.99	2.04	5.8	73
		Difference (Δ)	0.122	0.55	-0.04	0.20	0.31	-1.3	-2
	30mm / 90°	Before	0.423	3.81	0.23	0.55	1.77	6.5	78
		After	0.445	3.77	0.19	0.59	1.81	7.8	76
		Difference (Δ)	0.022	-0.04	-0.04	0.04	0.04	1.3	-2
	30mm / 180°	Before	0.468	4.39	0.14	0.62	1.83	5.8	76
		After	0.459	3.80	0.19	0.62	1.70	6.3	75
		Difference (Δ)	-0.009	-0.59	0.05	0.00	-0.13	0.5	-1
	30mm / 270°	Before	0.572	4.98	0.17	0.73	2.06	5.4	73
		After	0.580	5.16	0.27	0.84	2.14	8.5	75
		Difference (Δ)	0.008	0.18	0.10	0.11	0.08	3.1	2
Average at 30mm	Before	0.495	4.34	0.21	0.67	1.85	6.2	76	
	After	0.530	4.36	0.23	0.76	1.92	7.1	75	
	Difference (Δ)	0.036	0.03	0.02	0.09	0.07	0.9	-1	

It can be stated that coated surface has similar values than uncoated one; this assumption can be supported by a graphical analysis for Rk family parameters which is thoroughly used for characterizing honed surfaces, see details on the Figure 4.

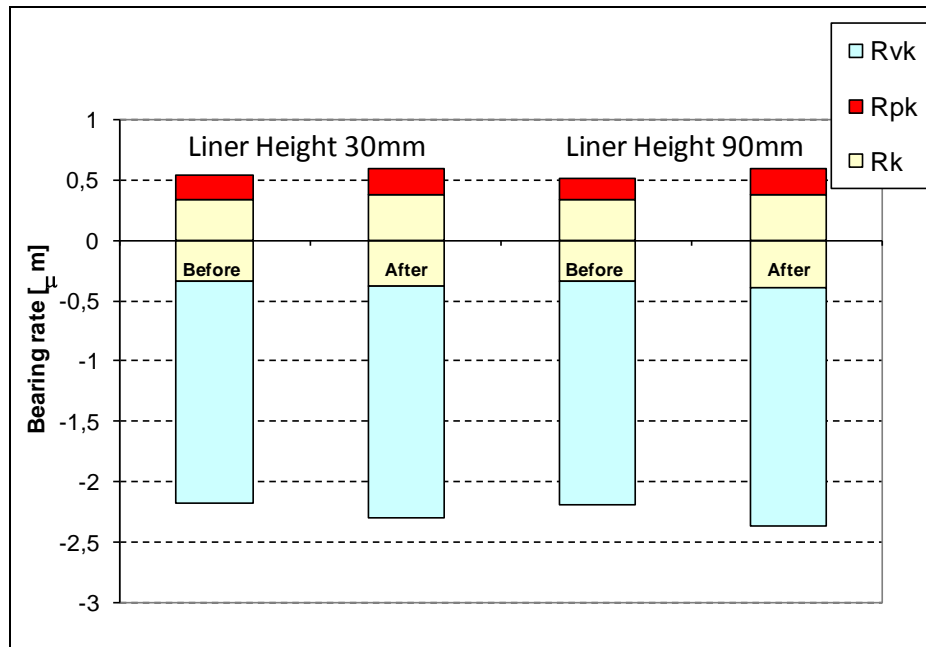

**Figure 4: Surface roughness characterization prior and after coating operation in 2 liner heights.**

Complementary analyses by fax film technique were performed to evaluate visually the surface topography in a comparative basis for coated and non coated surfaces. Figure 5 presents the findings and it clearly shows that honing marks are still on the coated surface. The fax-film results as well as the roughness measurements on the coated surfaces had maintained the original honing characteristics on the gray cast iron substrate. Consequently there is no need of post finishing process after applying DLC coating. All relevant geometrical features were also controlled prior and after deposition, i.e. roundness, straightness, internal and external diameters and no significant change was detected by the measurements, consequently the coating method is suitable for use on cylinders on ICE.

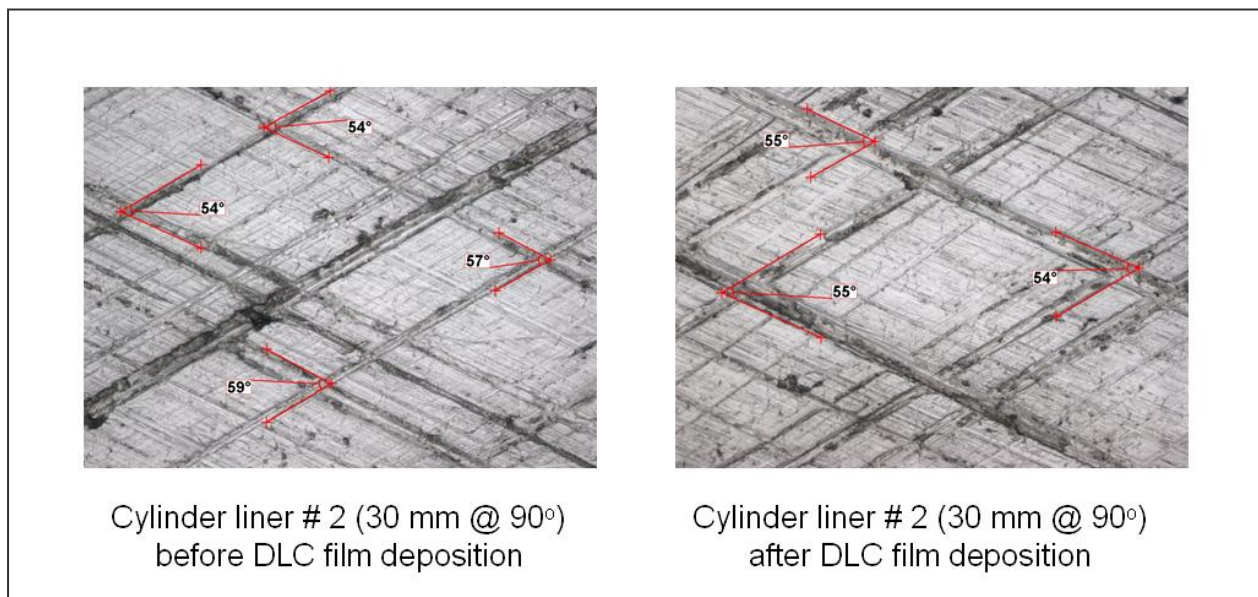

**Figure 5: Topography of the cylinder liner surface characterized by fax film technique.**

The 3.5 µm thick coating with hardness of 1250HV was produced in an environmentally and health friendly process. Coating characterization was performed by evaluating the cross sectioned samples via scanning electron microscopy (SEM) as presented on the Figure 6. The produced samples were evaluated in reciprocating bench test as well as in the fired engine test as detailed ahead.

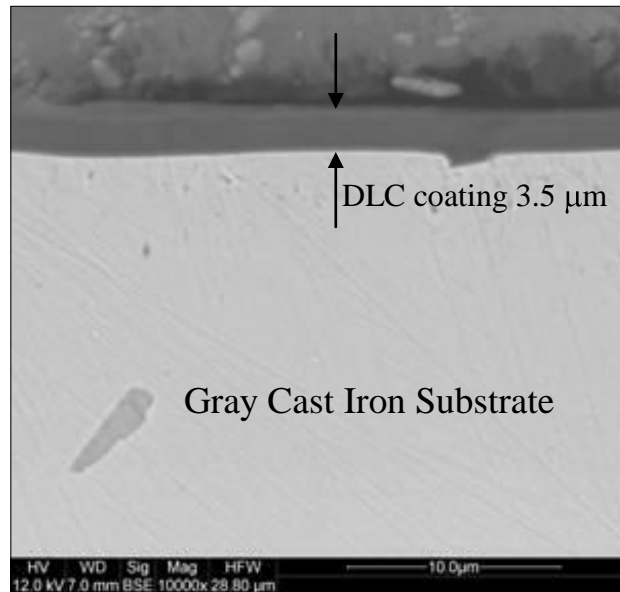
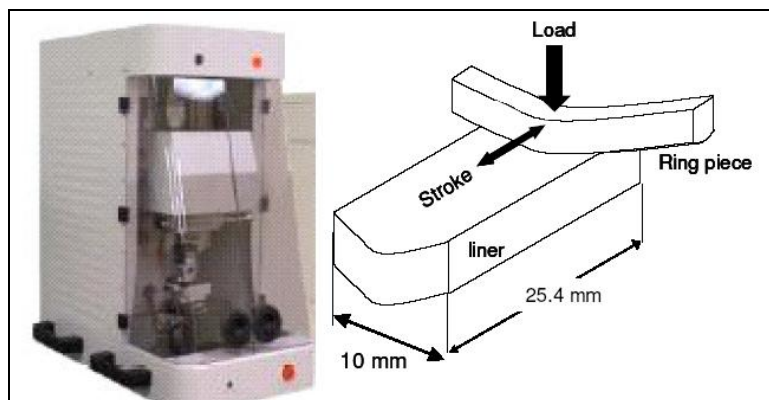

*Figure 6: Cross sectional view in SEM.*

## FRICITION BENCH TESTS

Friction tests were performed in a reciprocating tribometer (CETR UMT-2) able to measure friction coefficient (COF). The coated and non-coated specimens were obtained from the HDD cylinder liners. The counter parts were taken from actual piston rings used in the same engine application. The top piston ring (3,0 mm width) is coated with chrome nitride (CrN) applied by PVD process. During the test, a normal load is applied using a closed-loop servomechanism, the experimental setup is shown on Figure 7. A consequence of the applied normal load simultaneously to the sliding reciprocating movement is the frictional force, both normal and friction loads are measured by a load cell. For each cylinder liner version, four replications were performed according to the following procedure:

- Testing parts, cylinder liner and piston ring, were immersed in 20 ml of SAE30 lubricant oil.
- Testing temperature was controlled by the oil temperature at 120°C.
- Each specimen was submitted under a run-in cycle with a constant normal load of 360 N during 2 hours.
- The friction coefficient (COF) was measured in two different normal loads, 50 and 100 N, representing equivalent nominal pressure from the piston ring surface contact of 0.14 and 0.28 MPa respectively.
- At each normal load level, seven reciprocating speeds were set: 25, 50, 75, 100, 150, 250 and 375 rpm.
- To confirm if the proposed run-in cycle was effective for the COF measurements, it was repeated once again after two hours of test at 460 N of normal load and new measurements of friction coefficients were recorded and compared with the previous data.



*Figure 7 – Schematic configuration of the CETR UMT-2 tribometer for reciprocating tests.*

The developed testing procedure consists of measuring COF throughout 360° of the reciprocating movement at each reciprocating speeds, and the COF value was obtained as average of 100 cycles. In the sequence a Stribeck like curve was generated

for each cylinder liner variant. For simplicity, just COF values for normal load of 50 N are presented in the Figure 8. The 100 N load tests showed similar differences in all reciprocating speeds.

In the graph of Figure 8, the uncoated and coated liners are named “baseline” and “DLC” respectively, and the friction coefficient results are presented after 2 hours and 4 hours of run-in cycle.

The quite low reciprocating speed of 25 rpm was intentionally set to force lubricant condition towards boundary regime. The respective measured COF from the baseline and DLC coated liner specimen were 0.24 and 0.19 for lowest reciprocating speed. It’s also observed that COF tends to decrease with higher reciprocating speed as predicted by Stribeck curve, since at higher speeds the normal load is mainly supported by hydrodynamic effect reducing the asperity contact [5]. The comparison of the COF after the two or four hours after run-in did not show significant variation indicating an adequate bench test regime. Moreover the friction measured against DLC was lower than the bare cast iron in any tested speed. In average, the DLC coated liner showed 19% lower COF than the uncoated one.

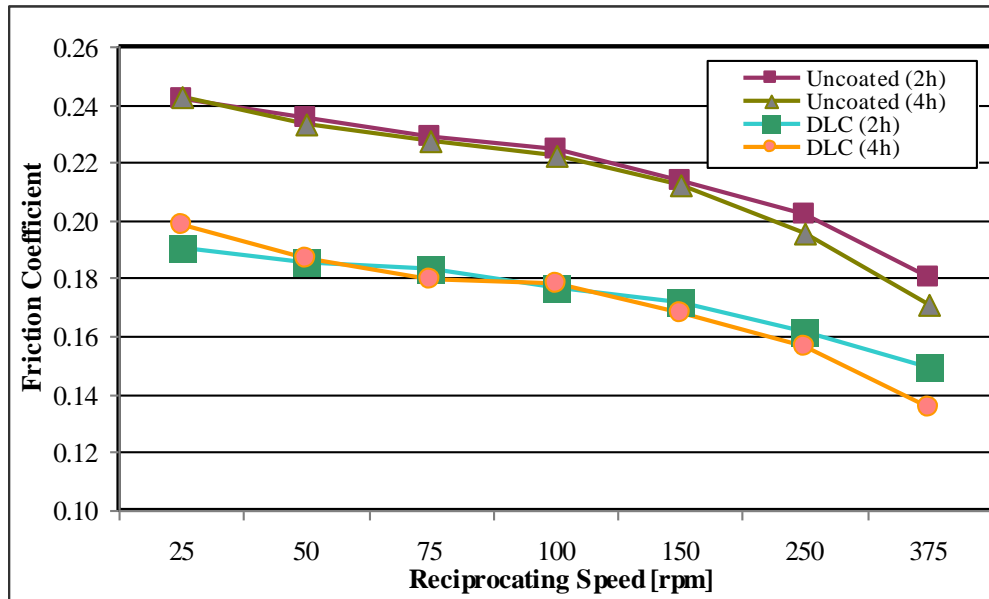

Figure 8 – Average measurement of COF for the coated & uncoated variants (50 N normal load cases)

## FUEL CONSUMPTION AND WEAR EVALUATION IN ENGINE TEST

Overall, the benefits of the low friction films can be more attractive by applying it on systems operating in conditions leading to asperity contacts. So an ICE presenting high mechanical loads simultaneously to low relative speed of the sliding surfaces was selected for demonstration of the benefits of DLC film for cylinder liners. Table 3 presents the main features of the selected HDD engine for the durability test.

Table 3 – Testing engine for qualification of DLC coated cylinder liners

<b>Engine type:</b>	<b>6 cylinders in-line, transversal installation</b>
<b>Fuel type:</b>	<b>Diesel</b>
Maximum peak combustion pressure:	22 MPa
Compression ratio:	18.5 : 1
Displacement:	12.8 L
Bore / Stroke:	131.0 mm / 158.0 mm
Rated power:	430 kW @ 1800 rpm
Rated torque:	2850 Nm @ 1200 rpm

To support the durability tests, a dyno cell equipped with AVL W700 load sensor was used with cell accuracy measurement of 1.5% of the actual value. The fuel consumption was measured by AVL 733S device with measurement accuracy of 0.1% of the actual measured value. The engine torque was monitored

Initially, a complete set of six coated cylinder liners were assembled inside the HDD engine to perform 20 hours of run-in cycle test. On this first step, the engine speed worked in range from 1200 rpm up to 1800 rpm in different torque conditions including full load. After such initial testing time, a total of 125 h of test was performed following nine points of operation conditions. During such short durability, the power, torque and specific fuel consumption were monitoring at full load condition in the engine speed range from 1000 rpm up to 2000 rpm. Finally, all coated liners were removed and a new set of uncoated cylinder liners were assembled so the same test procedure was performed.

Components clearance, rings tension, sliding profiles as well as surface finishing were measured prior and after tests in order to guarantee reliable comparison of the results presented in Figure 9.

The performance evaluation of the liners was made in two different speed ranges:

**a) Lower speed range (1000 - 1400 rpm):** In this running condition there was no significant variation of the corrected power and torque. On the other hand, a remarkable 2.5% reduction of the specific fuel consumption was observed when using low friction coated DLC liners.

**b) Intermediate and higher speed range (1400 - 2000 rpm):** In this running condition, no significant variation could be observed in the torque and power curves as well as in the specific fuel consumption curve. The slight shift of the curves was considered within accuracy measurement range.

Therefore the benefit of applying low friction DLC film is expected in the lower speed range (1000 – 1400 rpm). This is mainly influenced due to the high mechanical loads generated by the combustion and to the low running speed. In this regime, the low friction properties of the coating can be verified because of the asperity contacts.

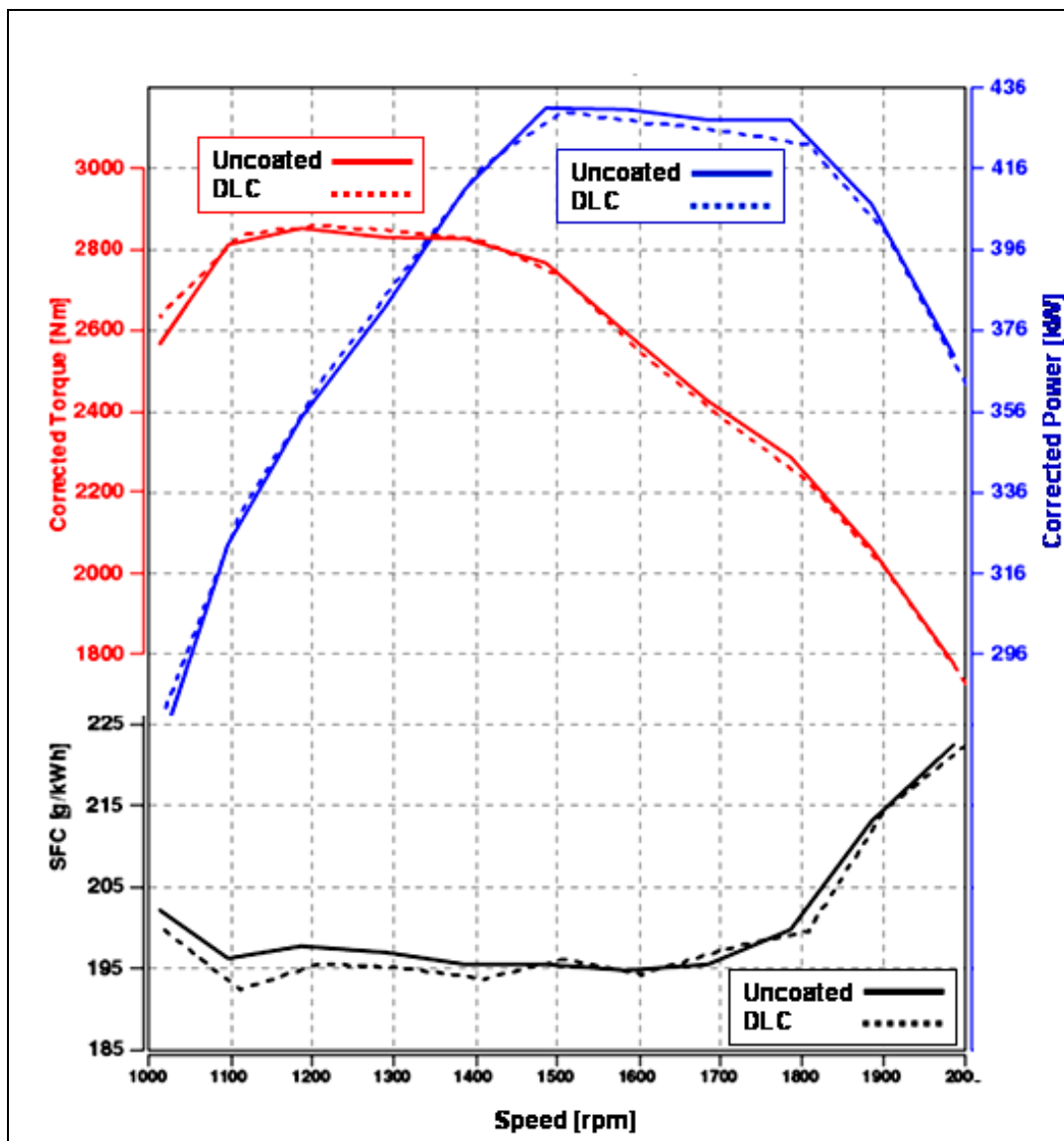

Figure 9 – Engine test results with a set of uncoated and coated cylinder liners



Not only the wear was measured but some other key features were taken into account to better characterize the performance of the new coated component. The lubrication oil consumption (LOC) was 21 g/h with coated liners set while uncoated liners set reached 26 g/h, both within usual approved range (maximum of 40 g/h). Blow by was also measured reaching the range from 140 up to 160 l/min for both cylinder liner configurations.

Tribological evaluation was performed by measuring wear after the short endurance test via 2D profilometer technique. Measurements were carried out at upper reversal point on the cylinder liner working surface which presents the worst working condition because of low relative sliding speed of the piston rings simultaneously to the maximum pressure of the top ring against cylinder liner due to combustion pressure which also heats up the upper region of the cylinder. Such work condition jeopardizes the oil film and consequently more intense interaction between asperities of the sliding surfaces usually generates wear on such region. Figure 10 shows representative wear profile measurements on the top dead center TDC region related to the reversal upper point of the top piston ring (1<sup>st</sup>) for coated and uncoated cylinder surfaces with higher wear for the latter one. It is also presented a picture of the liner working surface with DLC coating after the durability test. An interesting and unexpected result is related to the fact that there is no deposit of carbon build up occurrence above to the TDC region on all coated liners. The dashed line indications of 1<sup>st</sup>, 2<sup>nd</sup> and 3<sup>rd</sup> on the Figure 10 represent the reversal points of each piston ring respectively. It is clearly observed, especially for the 1<sup>st</sup> ring, there is some surface modification due to some wear on the surface but there is still remaining coating on such region as well as the honing grooves presence.

One may remark that adhesion of DLC coating is a key feature for successful application of such protective film due to its high internal stress that often hinders tribological application of DLC films. A proprietary deposition method generating ion implantation prior to coating growth as well as coating chemical composition showed to be feasible for the application of hard DLC coating onto soft cast iron substrate because no sing of coating delamination was detected even at highly loaded region at top dead center position of the cylinder liner.

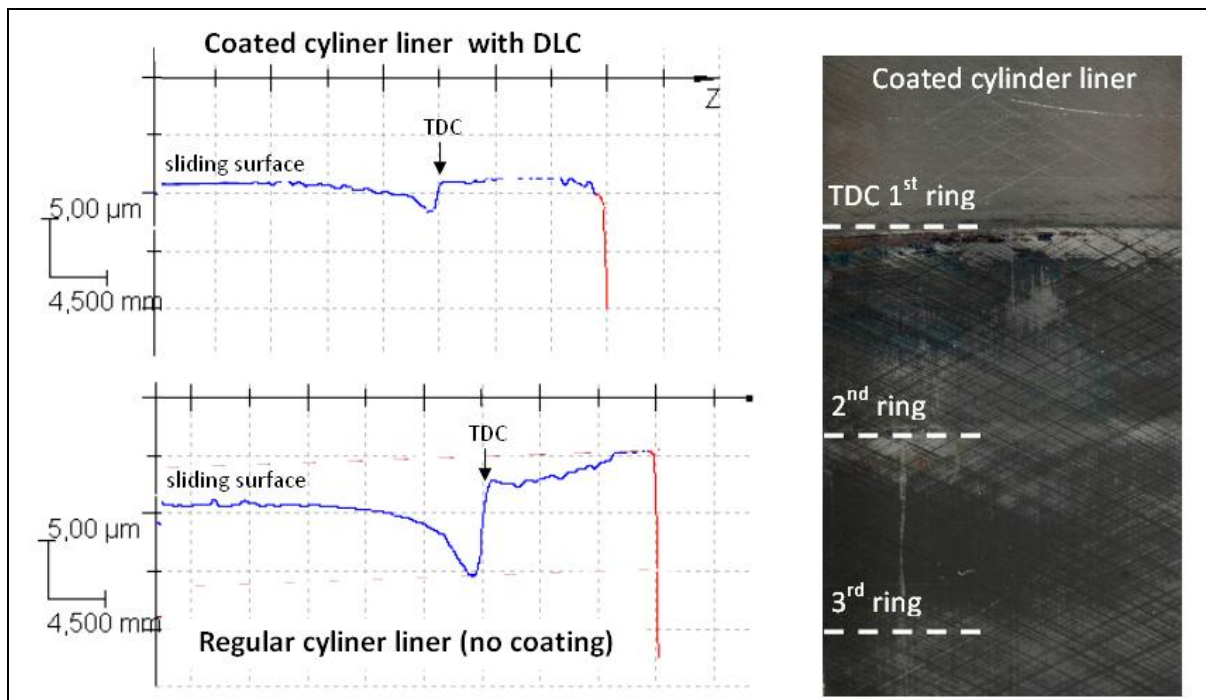

**Figure 10 – Wear measurement on TDC region and topography view of coated liner after test.**

For better wear evaluation each tested cylinder liner, coated and non-coated, was measured at four different angular positions in correlation with the HDD engine block and piston assembly positions, 0° (engine front side), 90° (piston anti thrust side), 180° (engine rear side) and 270° (piston thrust side). Not only cylinder liner wear was characterized but the top rings (1<sup>st</sup> ring) were also measured on the sliding contact surface by similar 2D profilometer technique before and after test so the piston ring wear behavior is characterized by the difference obtained from the superposing profiles of each sliding contact surface. On the Figure 11, the system wear results (combined wear between cylinder liners and piston rings) are presented as average value of the whole set of tested parts with standard deviation error bar. Even the DLC coated cylinder liners surfaces are considerably harder than the uncoated ones, an interesting tribological behavior could be observed when worked against top rings coated with CrN (by PVD process), so the verified system wear behavior looks better than with uncoated liners.

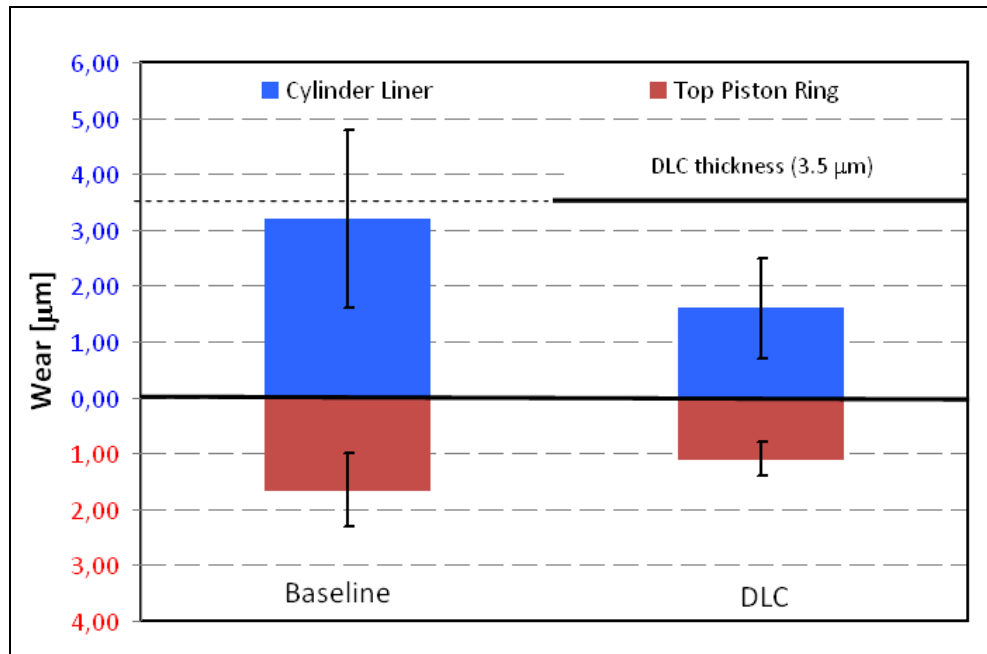

Figure 11 – Average cylinder liner wear measure on the TDC region correlated with the HDD engine assembly position.

## CONCLUSIONS

The HCPIIP process showed to be an efficient deposition method to apply DLC coatings on internal surface of cylinder liner with the advantage to coat a finished surface (honed surface) with no need of post finishing process because the coated surface keeps the original substrate topography characteristics.

DLC coating presented sound adhesion onto the gray cast iron substrate, firstly checked by metallographic analysis and also with extremely good response on the function tests with no signs of delamination on the tested surfaces.

The low friction property of DLC films was firstly demonstrated in a simplified reciprocating bench test showing friction reduction in the order of 19% in comparison to uncoated cylinder liner with same running roughness.

In the functional short durability engine test the better performance was obtained at lower engine speeds (up to 1400 rpm) with coated cylinder liners in a modern HDD engine. The comparative tests showed reduction of 2.5% in the specific fuel consumption due to lower losses for coated parts.

The proposed DLC coating applied onto cylinder liner working surface represents a high potential solution to reduce friction losses. It influenced directly the friction behavior of piston rings sets as well as on the pistons.

## REFERENCES

1. C. Öner, H. Hazar, M. Nursoy, K. Bobzin, "Surface properties of CrN coated engine cylinders". Materials and Design 2009;30: 914-920.
2. D. E. Richardson, "Review of power cylinder friction for diesel engines". Journal of Engineering for Gas Turbines and Power – ASME, October, 2000, vol. 122.
3. E. Tomanik, A. Ferrarese, "Low friction ring pack for gasoline engines". Proceedings of the ASME ICEF2006-1566, November, 2006, 5th-8th, Sacramento, USA.
4. J. Jocsak, et al. "The effects of cylinder liner finish on piston ring-pack friction". ASME paper ICEF2004-952, 2004.
5. E. Tomanik, "Friction and Wear Bench Tests of Different Engine Liner Surface Finishes". Tribology International 2008;41(11):1032-8.
6. R. Morgenstern, W. Kiessling, "Reichstein S., Reduced friction losses and wear by DLC coating of piston pins". Proceedings of the ASME ICES2008-1650, April, 2008, 27th-30th, Chicago, Illinois, USA.
7. A. Grill, "Diamond-like carbon: state of the art", Diamond and Related Materials, 1999;8: 428-434, New York, USA.
8. R. Schamel et al., "Amorphous Carbon Coatings for Low Friction and Wear in Bucket Tappet Valvetrains", SAE Paper 970004 (1997).
9. A. Erdemir et al., "Near-frictionless Carbon Coatings for Use in Fuel Injectors and Pump Systems Operating with Low-sulfur Diesel Fuels", SAE Paper 2000-01-0518 (2000)

10. H. Bewilogua, G. Bräuer, A. Dietz, J. Gäbler, G. Goch, B. Karpuschewski, B. Szyszka, "Surface technology for automotive engineering". CIRP Annals 2009 – Manufacturing Technology 58 (2009) 608-627.
11. M. Grischke, A. Hieke, F. Morgenweck, H. Dimigen, "Variation of the Wettability of DLC-coatings by Network Modification Using Silicon and Oxygen". Diamond and Related Materials (1998) 7:454–458.
12. H. Maciel S.et al., "Studies of Hollow Cathode Discharges Using Mass Spectrometry and Electrostatic Probe Techniques", 12th International Congress on Plasma Physics, 25-29 October 2004, Nice (France)
13. D. Lusk, M. Gore, W. Boardman, T. Casserly, K. Boinapally, M. Oppus, D. Upadhyaya, A. Tudhope, M. Gupta, Y. Cao, S. Lapp, "Thick DLC films deposited by PECVD on the internal surface of cylindrical substrates". Diamond and Related Materials 8 (1999) 428-434.
14. S. Uehara, "Overview of the new surface finishings for SI bores". SAE Paper 2007-01-2823(2007).

## **ACKNOWLEDGMENTS**

The authors welcome the opportunity to thank Sub One Company to provide the coated prototypes as well as the technical background on DLC film deposition process. Special gratitude is also to our MAHLE colleagues for the expedited support to conduct this investigation.

## **DEFINITIONS/ABBREVIATIONS**

COF	Coefficient of friction
DLC	Diamond like carbon
HCPIIP	Hollow Cathode Plasma Immersion Ion Processing
HDD	Heavy Duty diesel
ICE	Internal Combustion engines
PECVD	Plasma Enhanced Chemical Vapor Deposition
TDC	Top Dead Center