

Study of the Positioning Influence in the Water Activity Measurement during Leak Test of Iodine-125 Seeds

João A. Moura^{1*}, Anselmo Feher¹, Carlos A. Zeituni¹, Maria E. C. M. Rostelato¹, Wilson A. P. Calvo¹, Oswaldo L. Costa¹, Carla D. Souza¹, Dib K. Júnior² and Anderson R. Camargo³

1. Instituto de Pesquisas Energéticas e Nucleares (IPEN/CNEN - SP) Av. Professor Lineu Prestes 2242 05508-000 São Paulo, SP, Brazil

2. Universidade de São Paulo (USP Leste) Rua Arlindo Bettio, 1000 03828-000 São Paulo, SP, Brazil

3. Faculdade de Tecnologia de Sorocaba Departamento de Mecânica Av. Engenheiro Carlos Reinaldo Mendes, 2015 18013-280 Sorocaba – SP, Brazil

Abstract: In the prostate cancer treatment, brachytherapy with iodine-125 seeds has been used. Iodine-125 seeds are sealed radioactive sources, made by a titanium capsule containing the radioisotope inside. In the final phase of the seeds production, it is necessary to ensure that there is no leakage of the radioactive material. A leakage test is performed, immersing the seeds in water during 24 h and measuring the resulting activity in the water. This measurement is made in a sodium iodide detector. The immersion water is transferred to a plastic tube with a cap. The tube is placed by an automated positioning system, in the detector chamber. This study aims to determine the best positioning of the tube for the detection. It is also important to determine the influence of the positioning variation intrinsic of the automated positioning system during the iodine-125 seeds production. The results obtained will be used as a reference to adjust the equipment and process control system, in the production of the iodine-125 seeds.

Key words: Iodine-125 seeds, brachytherapy, prostate cancer treatment, leakage immersion test, automated positioning system.

1. Introduction

Brachytherapy iodine-125 seeds are sealed radioactive sources used in prostate cancer treatment, among others [1, 2]. The iodine-125 seed developed by the CTR (Radiation Technology Center) at IPEN (Nuclear and Energy Research Institute) [3] is made by welding both the extremes of a titanium tube, with a silver wire inside the tube. The welding is made by plasma or laser process [4, 5]. This silver wire contains iodine-125 adsorbed in its surface, resulting in a sealed titanium capsule with the radioisotope inside. Fig. 1 shows this type of seed. In the quality control routine during seed production, leakage tests are taken to detect any leakage of radioactive material from inside the titanium capsule, avoiding patient contamination [6].

Leakage tests are carried out according to the International Standard Organization- Radiation protection – sealed radioactive sources - ISO 9978 [7]. This standard recommends different methods of leakage tests applied to sealed radioactive sources. After a study carried out at CTR [8], it was decided by the immersion test.

The immersion test consists of three basic steps. In the first step, the sealed source (seed) is placed inside a plastic vial with water. The tube is placed in an ultrasound washing machine during 10 min. In the second step, the tube containing the seed and water is left to rest for 24 h. In the third step, the water is transferred to a new tube and the activity of the water is measured by positioning the tube containing the water inside a sodium iodide detector. The water activity below 185 Bq (5nCi) means there is no leakage in the sealed source. Activity above this value means there is leakage in the source and it must be segregated, according

*Corresponding author: João A. Moura, health technologist, research fields: automation systems, radioactive source production and brachytherapy.

Study of the Positioning Influence in the Water Activity Measurement during Leak Test of Iodine-125 Seeds

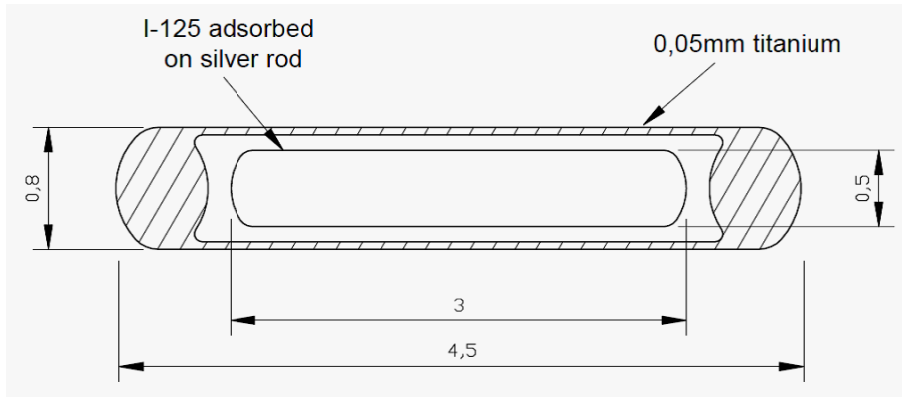

Fig. 1 Iodine-125 seed developed at IPEN.

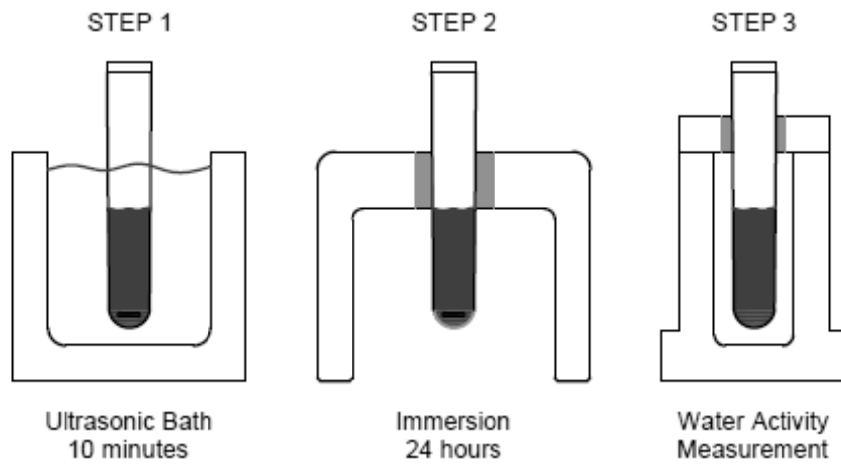

Fig. 2 The three steps of the leakage immersion test.

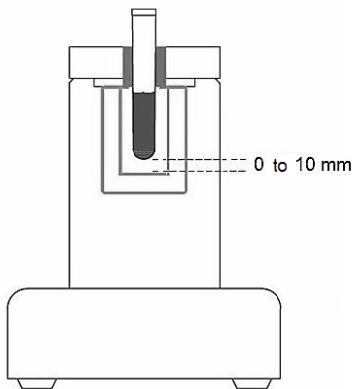

Fig. 3 Vertical positioning in the well detector.

to ISO-9978 standard. These three steps are represented schematically in Fig. 2.

The automated system is composed by electromechanical and mechanical devices, controlled by a computer. Those devices have intrinsic

positioning variations that may cause deviation of the activity measurement in the detector. To evaluate the influence of the positioning deviations in the measuring results, a series of assays were made.

2. Methodology of Assays

Two different assays took place to evaluate both vertical and horizontal influences of the positioning system.

2.1 Vertical Positioning Assay

This assay was about the influence of vertical positioning of the sample in the activity measurement. A tube containing 2 mL water and 5 nCi of iodine-125 was placed inside the sodium-iodide detector and changing the vertical position of the tube, relatively to the bottom of the well. A series of ten measures was

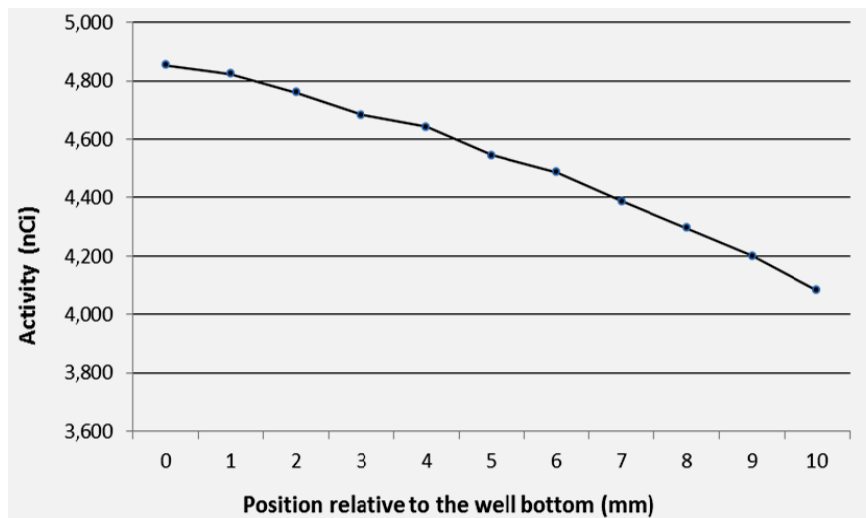

Fig. 4 Measured activity with variable vertical positioning in the well detector.

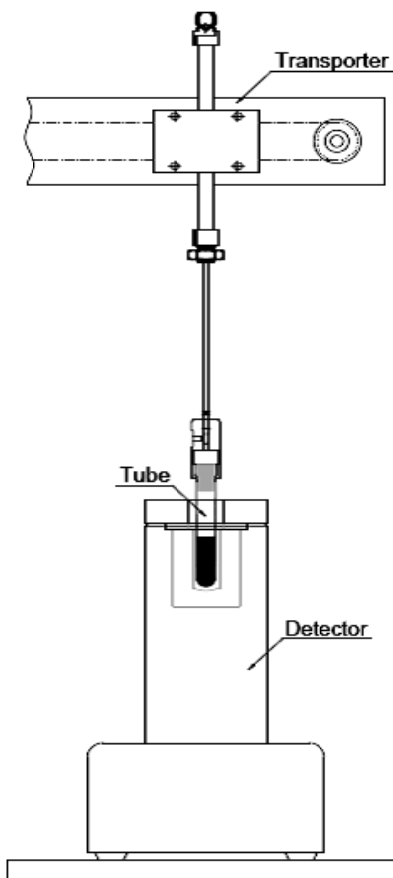

Fig. 5 Automated device to perform the sample positioning in the detector.

made for each 1 mm variation in the vertical position, beginning with position zero (tube in the bottom of the chamber) and ending with position, as it is represented in Fig. 3. The resulting average value of the 10

measurement for each positioning was plotted and is shown in Fig. 4.

2.2 Horizontal Positioning Assay

For this assay the vertical position of the sample was fixed in 2 mm above the bottom of the detector. This is due to the necessary clearance to prevent mechanical damage to the sodium-iodide chamber. The horizontal positioning assay was made in two different conditions. Initially the mechanical system was adjusted to put the tube with the sample inside the detector hole in its nominal horizontal center. Once adjusted, the assay consisted in repeat twenty times the entire process. This process consisted of four steps: First, the system takes the tube with the sample from a holding support; Second, the system move the tube to the hole and put it into the detector, third the system measures the activity; Finally, the system take off the tube from the detector and release the tube. This assay was called “dynamic assay”. After that, another assay was made. The second assay, called “static assay”, consisted in just one positioning cycle that had the activity measurement repeated twenty times without moving the sample. The positioning automated device is shown in Fig. 5.

The activity results obtained was plotted, for both “dynamic” and “static” assays and its influence in the

Study of the Positioning Influence in the Water Activity Measurement during Leak Test of Iodine-125 Seeds

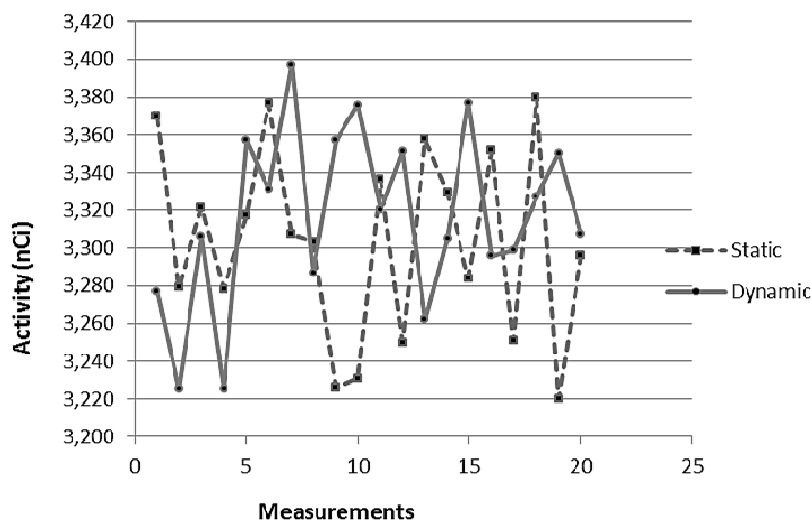

Fig. 6 Results obtained for both “static” and “dynamic” assays.

production process was evaluated. Fig. 6 shows the results.

3. Conclusions

The vertical positioning assay showed a strong influence of the vertical position of the sample relative to the bottom of the detector in the activity measurement. For this reason, the mechanical device must put the sample in the hole ensuring a minimum of vertical variation. The detector calibration must also be performed using the same vertical positioning as the work positioning, to prevent difference between activity values. Looking at the results obtained in the horizontal assay, by comparing the “static” and “dynamic” results, it is possible to conclude that the deviation due to the horizontal mechanical positioning system is not important. The deviation in the detector measurement (“static”) itself presented the same magnitude as the “dynamic” influence. Therefore, there is no reason to consider any correction factor or any special calibration procedure to compensate the horizontal positioning deviation, during the procedures of automated system work.

Acknowledgments

The authors are grateful to Fundação de Amparo à

Pesquisa do Estado de São Paulo – FAPESP for the financial support to the Iodine Seeds Project.

References

- [1] Davis, J. B. et al. 2012. “American Brachytherapy Society Consensus Guidelines for Transrectal Ultrasound-Guided Permanent Prostate Brachytherapy.” *Brachytherapy* 11: 6-19.
- [2] Podgorsak, E. B. 2005. “Radiation Oncology Physics: A Handbook for Teachers and Students.” International Atomic Energy Agency.
- [3] Rostelato, M. E. C. M. 2009. “Development and Production of Radioactive Sources Used for Cancer Treatment in Brazil”. *Nukleonika* 53 (2): 99-103.
- [4] Feher, A. 2006. “Development of a Procedure Using Plasma Welding Process to Produce 125I Seeds.” Master degree work. Nuclear and Energetic Research Institute. Universidade de São Paulo- USP.
- [5] American Welding Society. 1991. “Welding Handbook.” O’Brien, R. L. (Ed.) Welding Processes. 2: 10: 329-50.
- [6] International Atomic Energy Agency. 2001-2005. “Production Techniques and Quality Control of Sealed Radioactive Sources of Palladium-103, Iodine-125, Iridium-192 and Ytterbium-169.” IAEA-TECDOC-1512. Final Report of a Coordinated Research Project.
- [7] International Standard Organization. 1992. “Radiation Protection – Sealed Radioactive Sources – Leakage Test Methods.” ISO-9978.
- [8] Moura, J. A. 2013. “Leakage Test Methodology Development in Iodine-125 Seeds Production”. *Progress in Nuclear Energy* 62: 79-82.