

Single Frequency Oscillation in a Coupled Cavity Nd:GYLF Laser by Interferometric Control of the Cavity's Length

Paulo S. F. de Matos¹, Niklaus U. Wetter², and Gessé E. C. Nogueira

Centro de Lasers e Aplicações, Instituto de Pesquisas Energéticas e Nucleares

Travessa R, 400 Cidade Universitária, 00508-970, São Paulo, SP

¹ *psmatos@net.ipen.br*; ² *nuwetter@net.ipen.br*

Recebido em 18 de agosto, 2002. Versão revisada recebida em 28 de março, 2003. Aceito para publicação em 10 de abril de 2003.

Single frequency stabilization in solid-state laser resonators is essential for many applications as for example LIDAR or high-resolution spectroscopy. Nowadays there exists a whole new branch of lasers that are very well suited for these diverse applications, which are based on laser crystals optically pumped by high power semiconductor diodes. These lasers are very compact and have only minimal demands on the local infrastructure. We use a new technique, based on the combination of active and passive stabilization techniques, which allows us to achieve a greatly enhanced frequency selectivity. Using a high power diode, operating at 792 nm, we pump longitudinally a Nd:GYLF laser crystal. This new crystal can be made very small without reducing its efficiency and therefore the overall cavity length is also very small (less than one cm). With an electro-strictive actuator we stabilize as few as possible laser resonator modes. This is done by detuning the spectral hole burning modes (SHB) of the laser crystal from the cavity modes through nanometric adjustment of the cavity length and crystal position. Finally the effective reflectivity of the coupled cavity is adjusted to give high loss for all remaining frequencies except one. This is to our knowledge the first report of Nd:YGLF laser operation and single-frequency tuning.

A estabilização em frequência única em lasers de estado sólido é essencial para muitas aplicações, como por exemplo, LIDAR e espectroscopia de alta resolução. Atualmente existe toda uma nova área de lasers que são bem adequados para estas diversas aplicações, baseados em cristais laser bombeados opticamente por diodos-laser. Estes lasers são muito compactos e têm mínimas demandas de infra-estrutura local. Foi usada uma nova técnica baseada na combinação de técnicas de estabilização ativa e passiva, o que permite alcançar um grande aumento da seletividade de frequência. Usando um diodo de alta potência, operando em 792 nm, foi bombeado longitudinalmente um cristal laser de Nd:GYLF. Este novo cristal pode ser feito muito pequeno sem reduzir sua eficiência e, desta forma, o comprimento total da cavidade é também muito pequeno (menor que um centímetro). Com um atuador piezo-elétrico, foi estabilizado o menor número possível de modos do ressonador laser. Isto é feito dessintonizando os modos de spectral hole burning (SHB) do cristal dos modos da cavidade através do ajuste nanométrico do comprimento da cavidade e da posição do cristal. Finalmente, a refletividade efetiva da cavidade acoplada é ajustada para dar alta perda para todas as frequências remanescentes, exceto uma. Pelo que sabemos, esta é a primeira vez que se obtém operação laser e sintonia de frequência única com o cristal Nd:YGLF.

1 Introduction

Diode pumped solid-state lasers (DPSS) have increased their range of applications as a function of their operational advantages in relation to lamp pumped solid-state lasers. At the same time that a price reduction of the diode-lasers occurs, there has been also an increase in the market of diode-lasers due to products with more power and new wavelengths. A solid-state laser generally oscillates simultaneously on several longitudinal modes, depending on the cavity size and the gain profile inside the active material. The

development of laser stabilization techniques to achieve single frequency is important for several areas of science and technology. For example, it is necessary that the laser emits in a single, steady frequency in applications such as LIDAR (Light Detection And Ranging) for atmospheric measurements, in high-resolution spectroscopy and in communications technology [1-5].

There are several techniques to achieve single frequency operation in solid-state lasers, such as ring lasers [6, 7], microchip lasers [8, 9] and insertion of an intracavity etalon [10]. Ring lasers are generally used to achieve a very nar-

row frequency emission and are quite complex laser systems which incorporate expensive and elaborate techniques to achieve unidirectional propagation of the laser oscillation inside the resonator. End-pumping Lasers using intracavity wavelength selecting techniques tends to be inefficient due to the additional losses introduced by the wavelength selecting device.

Microchips are small laser resonators with high reflectivity films that are deposited directly onto the active medium, making cavities with dimensions of few millimeters possible. This technique only works for crystals with very high absorption coefficients. To get single frequency operation with a microchip laser it is necessary that the cavity mode spacing is larger than the width of the emission band of the active medium. As the cavity mode spacing is inversely proportional to the cavity length this results generally in cavities of less than one millimeter, which tends to result in incomplete and inefficient absorption of the pump light. The optical pumping with diode-lasers is extremely efficient and can compensate to some degree the above described deficiency due to the good spectral overlap of the diode emission with the main absorption bands of the active media. In longitudinal pumping schemes there is also good mode-matching between the diode's pump beam and the intracavity laser beam. For these reasons extremely small crystals may be used.

In order to stabilize one frequency, it is necessary that the variations caused by the environment are minimized constructing rigid and mechanical steady structures with anti-vibration systems, using material of low thermal expansion inside the cavity and by controlling the temperature of the environment. However this stability is of short period and, therefore, the use of active stabilization by means of adjustable optic components is necessary for long time stabilization. Closed-loop systems based on piezoelectric actuators can be used to correct mechanical vibrations from few Hz to kHz range, as well as very slow thermal induced fluctuations.

In this work a crystal is used which is long enough for the efficient absorption of the pump beam. The laser is longer than a microchip laser, permitting therefore higher output powers. Due to the larger cavity we can incorporate better mode selecting techniques that allow smooth tuning over a large spectral interval. In order to achieve single frequency operation we incorporate an additional cavity coupled to the main one [11]. This coupled cavity functions as Fabry-Perot (FP) and controls the reflectivity profile of the laser output through mechanical adjustment of the mirror separation. Other controls inside the main cavity permit the selection of the longitudinal mode frequency and the achievement of single frequency operation.

2 Theory

The frequencies that may be emitted by a laser are determined by the modes of the cavity, which depend on its size.

For a cavity with two flat mirrors, the separation between the modes, called free spectral range, is given by equation 1 [12] :

$$\Delta\nu_{cav} = \frac{c}{2nL_{cav}} \quad (1)$$

where c is the speed of the light in the vacuum, n the refractive index of the material inside the cavity and L_{cav} the size of the cavity. If the cavity is short enough in order that the free spectral range (the frequency difference between two consecutive maximums) is larger than the bandwidth of the laser, $\Delta\nu_{em}$, only the cavity mode inside the emission spectra will oscillate, as shown in figure 1.

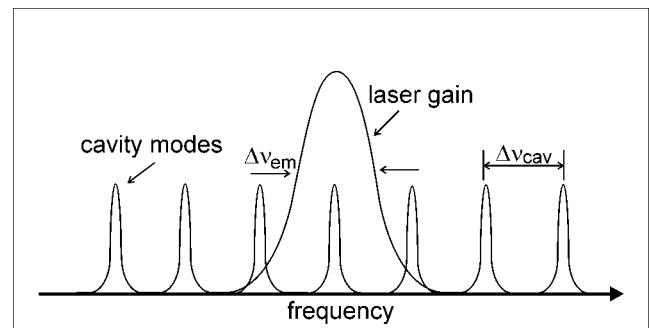

Figure 1. Scheme of longitudinal modes in a microchip cavity.

An oscillating mode inside the gain media establishes a modulation of the inversion population due to its standing wave pattern. The inversion population that is not exploited by the stationary electric field can contribute to the development of new oscillating modes. These frequencies are called spatial hole burning modes (SHB).

The SHB modes are determined by the size of the crystal and its distance to the nearest cavity mirror [13, 14]. Their frequency separation is given by equation 2,

$$\Delta\nu_{SHB} = \frac{c}{2(2d + nL)} \quad (2)$$

where d is in the distance of the crystal end face to the nearest cavity mirror, n the refractive index of the active material and L its size. By tuning the position of the crystal the SHB modes can assume any frequency within the gain bandwidth. Laser action happens only at frequencies where coincidence between a cavity mode and a SHB mode occurs. The cavity mode that will first oscillate is the one closest to the frequency of the gain peak of the active medium. The following mode to oscillate will be in anti phase with the first mode in the center of the active medium in order to best use the remaining non-inverted population inside the active medium. By tuning the main cavity length, a frequency shift of the cavity modes is introduced, one of which eventually coincides with a SHB mode that then initiates its oscillation.

Other factors that determine the frequencies that can be obtained are the emission bandwidth the pumping power and the profile of the reflectivity of the output mirror. The Nd:YGLF crystal used in this work has a large gain bandwidth (360 GHz) [15]. Due to its large bandwidth this crystal would generally oscillate on several SHB modes even for

sub-millimeter cavity length. Using a coupled FP cavity instead of one output mirror allows selecting a reflectivity profile of the output coupler with adjustable width. For two flat mirrors with reflectivity of R_1 e R_2 , the reflectivity profile is given by [16]:

$$R_{eff} = \frac{(\sqrt{R_1} - \sqrt{R_2})^2 + 4\sqrt{R_1 R_2} \sin^2(\delta/2)}{(1 - \sqrt{R_1 R_2})^2 + 4\sqrt{R_1 R_2} \sin^2(\delta/2)} \quad (3)$$

where

$$\frac{\delta}{2} = \frac{2\pi n d}{\lambda} \cos \theta \quad (4)$$

being d the distance between the coupled cavity mirrors, λ the wavelength, n the refraction index and θ the beam incidence angle. The variation of the effective reflectivity modulates the gain profile of the laser as shown in figure 2. By choosing a reflectivity profile whose maximum is equal to the optimum reflectivity of the laser, the SHB frequencies that are at the maximum will have the highest gain whereas the other SHB frequencies suffer higher losses and may be suppressed. Ideal conditions occur when only one SHB mode coincides with a reflectivity maximum. If there are too many SHB modes, it may be necessary to lower the pump power in order to achieve single frequency.

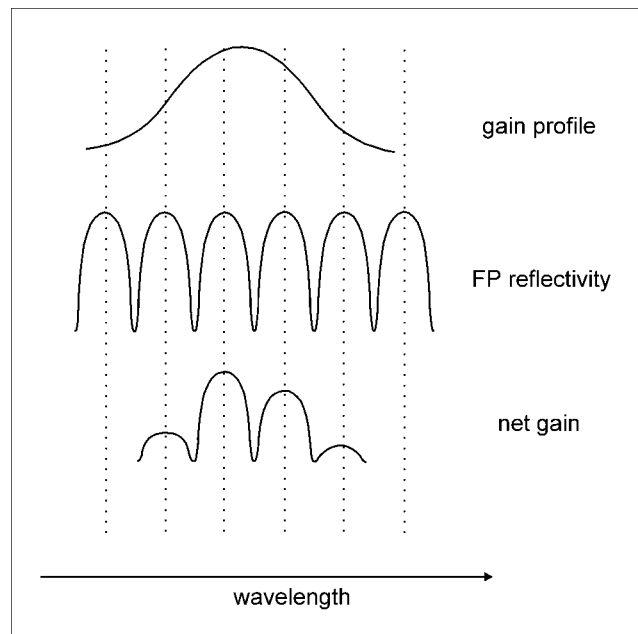

Figure 2. Scheme of the gain profile, the output reflectivity profile of the FP and of both together.

Therefore, selection of a specific single frequency requires several steps: Tuning of one SHB mode to that frequency, suppression of all the other SHB modes by convenient adjustment of the coupled cavity size and reflectivity, detuning of the main cavity and adjustment of the pump power. In practice, once the pump power and the reflectivity of the coupled cavity are established, only the two cavity lengths and the crystal position are adjusted.

In the case of diode-laser pumping, local power variations inside the active material cause temperature fluctuations and also refractive index changes, thus moving the optic path of the laser. Together with acoustic vibrations, these variations set a not intrinsic lower limit for the linewidth of the emitted single frequency. The intrinsic linewidth, given by the well known Schawlow-Townes formula, is of the order of a couple of Hz and is much smaller. The variation of the frequency with time depends on cavity size variation (ΔL) and refractive index variation of the medium (Δn), given by the equation 4:

$$\Delta\nu(t) = -\frac{\nu_0}{n_0 L_0} [n_0 \Delta L(t) + \Delta n(t) L_0] \quad (4)$$

The emitted frequency is about 3×10^{14} Hz for this laser. The right hand side of the formula was estimated to be at the most 10^8 Hz. This is in agreement with the linewidth we measured in the next section and shows clearly that ambient influences determine the observed linewidth.

3 Experimental setup and results

In this work, a 20 W AsAlGa diode bar laser (OPC-A020-mm-CN Opto Power, 24 emitters) was used, emitting at 25 °C with 3 nm of bandwidth and centered at 792 nm. This pump source is matched to the σ absorption band of the neodymium ion transition from $^4I_{9/2}$ to $^4F_{5/2}$. The crystal host is made of lithium, yttrium and gadolinium fluoride (GYLF) that allows for high doping levels with neodymium, which is important in order to have efficient absorption. The peak emission is at 1047 nm. The active medium was cut at Brewster angle and had a length of 2.9 mm, which absorbed approximately 90 % of the incident pump power. The pump beam was configured as shown in figure 3, in order to achieve good mode matching between pump beam and intracavity laser beam [17]. The pump beam had horizontal and vertical quality factors of approximately $M_x^2 = 43$, $M_y^2 = 62$ and beam waist of $135 \times 160 \mu\text{m}$, respectively. Although the pump set-up is quite complicated, it generally stays aligned for several month and only a slight readjustment of the position of the focusing lens, f_{xy} , is necessary every couple of days. The causes of frequency fluctuations can be divided in those of long period, of the order of several seconds, caused by temperature and pressure variations in the laser environment and those of short period, that include acoustics vibrations of the mirrors and refractive index changes of the active medium due to the diode-pumping. Most of these vibrations can be damped with the help of antivibration systems. We used a Newport Vibration Control System that isolates the table top for frequencies higher than 1 Hz from the floor motion, using pneumatic suspension systems. At 10 Hz, the system attenuates already in 90% the through coming floor vibration.

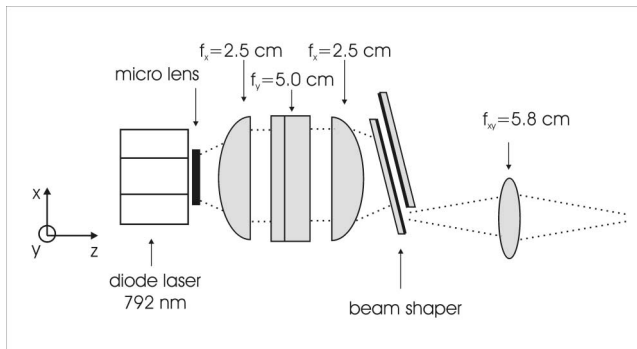

Figure 3. Pump diode laser and focalization optics.

The experimentally established optimum reflectivity for the output mirror was 88%. For this reason, a set of mirrors was chosen for the coupled cavity, whose maximum effective reflectivity was close to this value as shown in figure 4 and figure 5. The input mirror of the main cavity had a radius of curvature of 20 cm and the coupled cavity FP is formed by two flat mirrors with reflectivities of 70 and 48 %. The high reflectivity coating of the intermediate mirror faced the coupled cavity. Therefore, the main cavity length of 12 mm includes the mirror substrate. By means of a piezoelectric actuator with precision of nanometers the size of the main cavity could be adjusted, whereas crystal position and coupled cavity length were adjusted with the help of differential micrometers. The laser's frequencies were analyzed by a scanning etalon (Burleigh HiFase), coupled to a digital oscilloscope that displayed the emitted frequencies in real time.

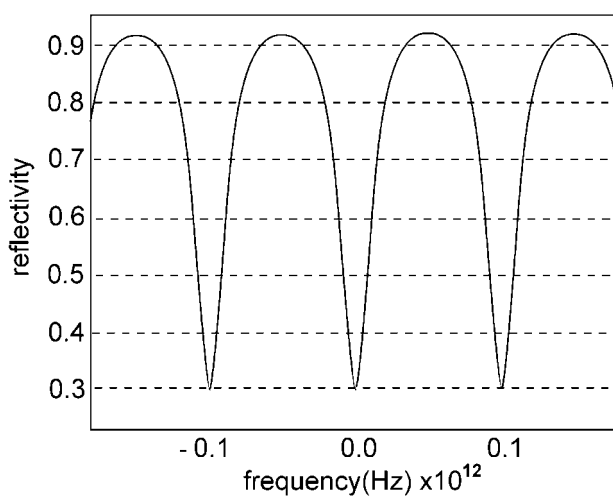

Figure 4. Effective reflectivity as a function of frequency for a Fabry-Perot coupled cavity with flat mirrors of 70 % and 48 % reflectivity and separation of 1.5 mm.

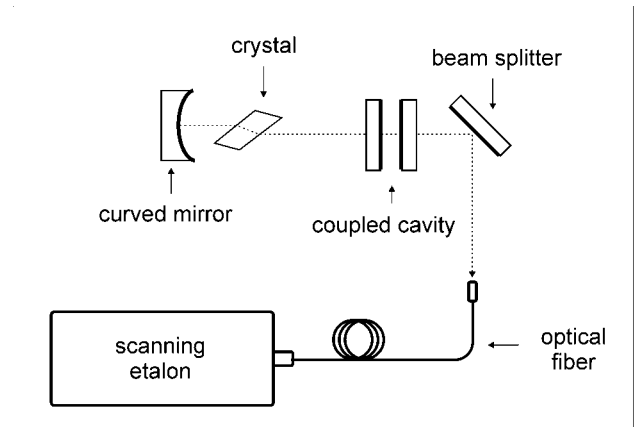

Figure 5. Schematic diagram of the cavity set-up.

Emission of a single frequency was displayed on the oscilloscope as shown in figure 6. As expected, the linewidth of the trace was less than the minimum resolvable bandwidth of our scanning etalon (150 MHz). The oscilloscope readout was calibrated using the procedure described in the scanning etalon's manual, based on the measurement of the ratio between the frequency separation of two adjacent etalon transmission modes, $\Delta\nu_{01}$, and etalon free spectral range (FSR), as shown in figure 7. Generally we did not go through the cumbersome re-alignment procedure of the scanning etalon for complete mode-matching after each change in the laser's cavity set-up, which is only necessary when the linewidth of the frequency needs to be determined. Therefore, higher order etalon transmission modes appeared on the screen that could easily be distinguished from other SHB modes of the laser, as shown in figure 8.

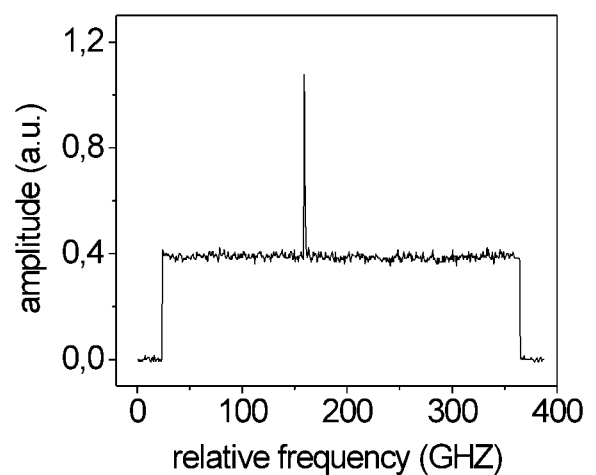

Figure 6. Single frequency operation as seen on the oscilloscope readout.

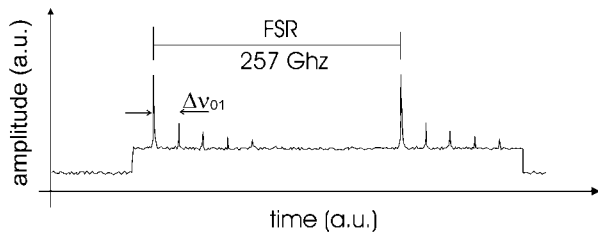

Figure 7. One single scan of the etalon. The two bigger peaks represent the same frequency, ν_0 , appearing two times because the scan amplitude of the etalon is larger than $c/2\nu_0$. The smaller peaks are higher order transmission modes of the scanning etalon.

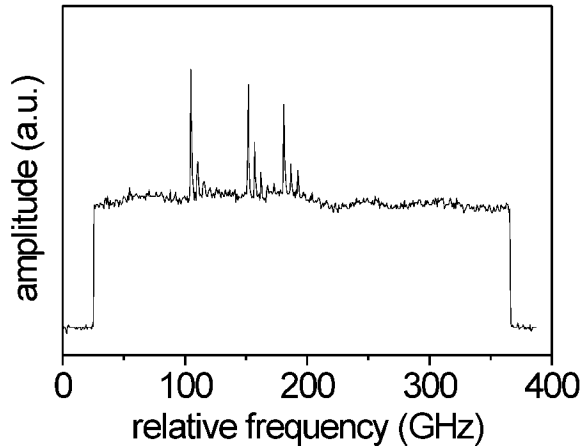

Figure 8. Scan without the coupled cavity, showing 3 frequencies of SHB.

Without the coupled cavity, the increase of the pumping power provoked the appearance of at least three to five SHB modes, as shown in figure 8. In figure 9 an acquisition of the three frequencies of figure 8 during a period of 15 seconds demonstrates the effect of the thermal and mechanical instabilities when the table top is not isolated from the ground. With the table top isolated, we could achieve up to 30 minutes of stable operation of the same single frequency only by periodically readjusting the main cavity length every 5 minutes with the piezo actuator. We also used the stabilization circuit of the HiFase System to automatically compensate for thermal drift effects and thereby keep a selected frequency centered on the oscilloscope screen. Single frequency stabilization could be achieved for even longer periods by means of the piezoelectric actuator and an active control system to correct the laser cavity length. That is, we observed that a single mode waveform displayed on the oscilloscope was stable for at least several seconds. By means of a temporal window, selecting only the descending part of the waveform (or alternatively the ascending part), a prefixed amplitude can be used as a reference to achieve an error signal. The error signal is then used to provide an active feedback control signal to maintain the piezoelectric actuator continuously adjusting the cavity length. Piezoelectric stacks can produce displacements of various microns, and

its time response is of the order of a few milliseconds. Since electronic systems can easily perform the necessary overall time response, such active stabilization is viable.

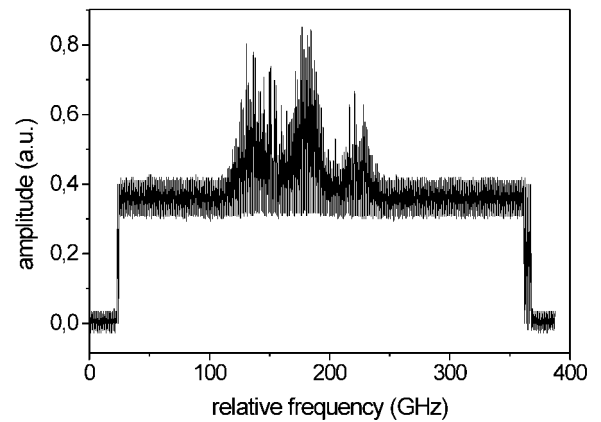

Figure 9. Repeated acquisition of scans during a 15 seconds without stabilization of the table top.

The effect of the reduction of the pump power for the purpose of achieving single frequency can be seen in figure 10. Only a very small output powers of the order of a couple of mW can be achieved in this way. With the coupled cavity and using the explained hole burning mode suppression techniques, it was possible to increase the pump power to 2.8 W obtaining a useful output power of 200mW. The frequency tuning achieved when the size of the coupled FP is changed in intervals of several tens of nanometers is shown in figure 11. Although a large tuning interval of almost 200 GHz is achieved, the output is not always single frequency. To achieve real single frequency operation the main cavity length has to be adjusted too as shown in figure 12.

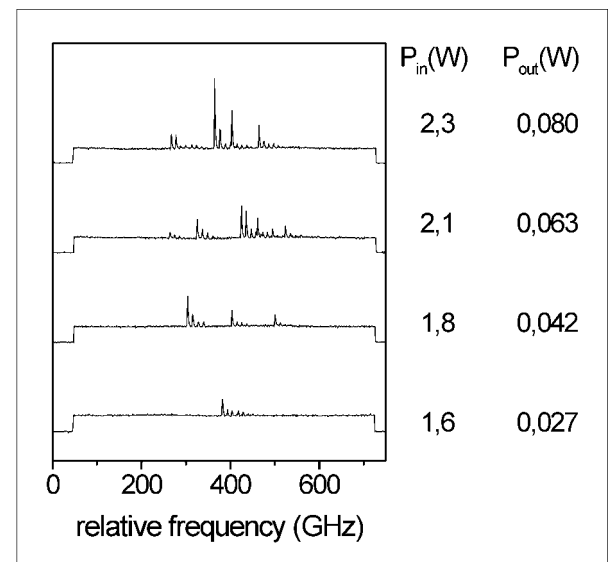

Figure 10. Dependence of the number of lasing SHB modes as a function of pump power.

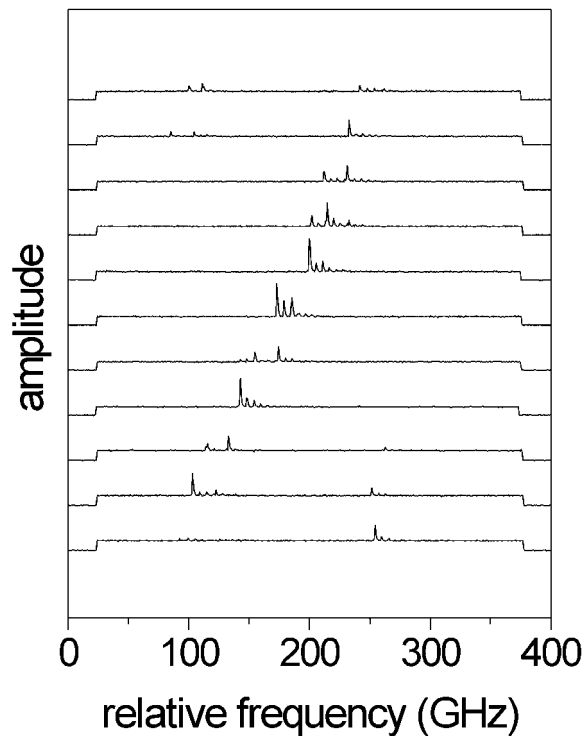

Figure 11. 12 scans obtained by changing the coupled cavity length of 1 mm by several tens of nanometers between each scan.

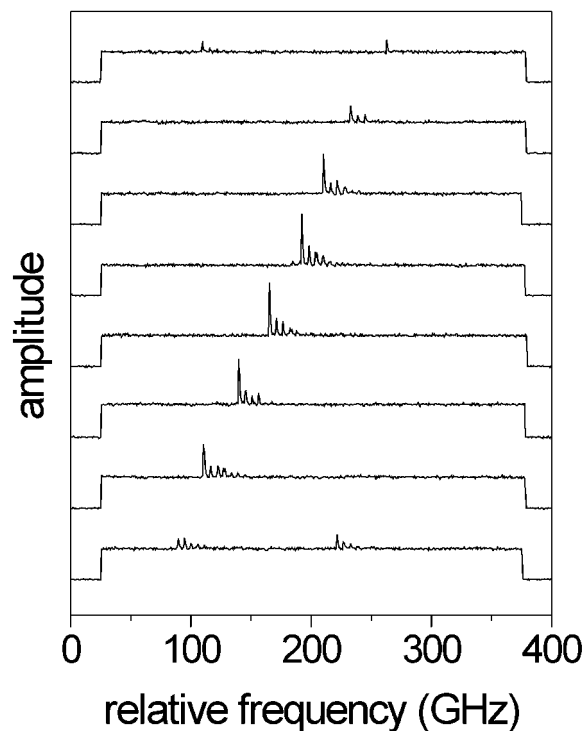

Figure 12. 8 scans obtained by the combined procedure of wave-length selection with the coupled cavity and SHB mode suppression through fine adjustment of the main cavity length.

4 Conclusion

We report on the construction and operation of a new, diode-pumped Nd:GYLF single frequency laser. The compact cavity design is easy to operate and allows to tune over a large bandwidth of 200 GHz by controlling only the size of two cavities. When controlling also the crystal position, smooth fine-tuning without mode hopping is achieved. A maximum output power of 200 mW was obtained for 2.8 W of pump power and remained stable for up to 30 minutes.

5 Acknowledgements

We would like to thank the “Fundação de Amparo à Pesquisa do Estado de São Paulo” (FAPESP) for the financial grant 95/9503-5, modality “Jovens Pesquisadores”.

References

- [1] Taczak, T. M., Killinger, D. K., Development of a tunable, narrow-linewidth, cw 2.066 μm Ho:YLF laser for remote sensing of atmospheric CO₂ and H₂O, *Appl. Opt.* **37**, 8460-8476 (1998)
- [2] Huffaker, R. M., Reveley, P. A, Solid-state coherent laser radar wind field measurement systems, *Pure Appl. Opt.* **7**, 863-873 (1998)
- [3] Nikitichev, A. A., Stepanov, A. I., 2- μm lasers for optical monitoring, *J. Opt. Technol.* **66**, 718-723 (1999)
- [4] Kalisky, Y., New trends in lasers and laser crystals, *Opt. Materials* **13**, 135-139 (1999)
- [5] Steele, R., The laser marketplace 2000 – part II: diode lasers, *Laser Focus World* **36**, 52-27 (2000)
- [6] Park, J. R. *et al*, Unidirectional single-mode Nd:YAG laser with a planar semimonolithic ring cavity, *Appl. Opt.* **38**, 4566-4569 (1999)
- [7] Hardman, P. J., Clarkson, W. A., Hanna D. C., Efficient operation of an acousto-optically-induced unidirectional and single-frequency Q-switched Nd:YLF ring laser, *OSA TOPS Advanced Solid-State Lasers* **26**, 236-240 (1999)
- [8] Zayhowski, J. J., Microchip lasers, *Opt. Materials* **11**, 255-267 (1999)
- [9] Bourdet, G. L., Lescroart, G., Theoretical modeling and design of a Tm,Ho:YliF₄ microchip laser, *Appl. Opt.* **38**, 3275-3281 (1999)
- [10] Elder, I. F., Payne, M. J. P., Single frequency diode-pumped Tm,Ho:YLF laser, *Electr. Lett.* **34**, 284-285 (1998)
- [11] Yokozawa, T., Izawa, J., Hiroshi H., Mode control of a Tm:YLF microchip laser by a multiple resonator, *Opt. Comm.* **145**, 98-100 (1998)
- [12] Kogelnik, H., Li, T., Laser Beams and resonators, *Appl. Opt.* **5**, 1550-1567 (1966)
- [13] Kärtner, F. X., Braun, B., Keller, U., Continuous-wave mode-locked solid-state lasers with enhanced spatial hole burning, *Appl. Phys. B* **61**, 569-579 (1995)

- [14] Vieira Jr, N. D., Mollenauer, L.F., Single-frequency, single-knob tuning of a cw color center laser, *IEEE J. Quantum Electr.* **QE-21**, 195-201 (1985)
- [15] Ranieri, I. M. *et al*, Growth and characterization of $\text{LiGd}_{1-x-y}\text{Y}_x\text{Nd}_y\text{F}_4$ single crystals, *J. Crystal Growth* **217**, 145-150 (2000)
- [16] K M Abramski, D R Hall, "Frequency stabilisation of lasers", *The Physics and Technology of Laser Resonators*, editado por D.R. Hall e P.E. Jackson, IOP Publishing Ltd 1989
- [17] Wetter, N. U., Three-fold effective brightness increase of laser diode bar emission by assessment and correction of diode array curvature, *Optics and Laser Technology* **33**, 181-187 (2001)