

# CONSTRUCTION AND CHARACTERIZATION OF A HOLLOW CATHODE TUBE FOR HIGH SENSIBILITY LASER SPECTROSCOPY

A. Mirage and C.C. Motta\*

Instituto de Pesquisas Energéticas e Nucleares IPEN/CNEN  
Travessa R 400. São Paulo - SP - 05508-900

e-mail: amirage@net.ipen.br

\*Centro Tecnológico da Marinha em São Paulo CTMSP

Av. Prof. Linco Prestes 2242. São Paulo - SP - 05598.900

e-mail: ccmotta@baitaca.ipen.br

COLEÇÃO PTC  
Devolver no Balcão de Empréstimo

Key-words: Electric discharges, plasma physics,  
laser spectroscopy

## ABSTRACT

A new hollow cathode tube argon-iron design was developed to be used in laser atomic spectroscopy experiments, where high sensibility is required. This tube was employed in order to allow laser absorption and optogalvanic signal measurements. The tube also included fused-quartz Brewster angle windows aligned with the optical axis in each ending of the tube. Therefore, in this configuration a minimum laser intensity losses through the windows can be attained for the appropriate light polarization. The optogalvanic signal detection was accomplished using a tunable dye laser resonant with the Ar,  $3p^5 4p(^3S_1) \rightarrow 3p^5 4d(^3D_1^o)$  transition, that corresponds to 591.2 nm in air. It was also possible to determine the gas temperature by measuring the Doppler line broadening and the results were compared to those obtained from a theoretical model for gas heat conduction. To measure the temperature of the cathode external surface a thermocouple was used inside the tube. The analysis of results showed that a high signal to noise ratio can be obtained with this tube configuration, that permits experimental investigation of electronic transitions presenting low light absorption cross sections.

## 1. INTRODUCTION

Light-matter interaction can be investigated both theoretically and experimentally using a rare gas plasma produced by electric discharge, where a tunable laser radiation induces electronic transitions in the plasma atoms. Metal atom vaporization can be easily obtained through electric discharges in a hollow cathode configuration. In this type of tube the cathode itself is used as the element to be analysed. Hollow cathode tubes (HCT) are characterized by low temperature metal vaporization, sputtering processes, where accelerated rare gas ions collide with cathode surface, producing free metal atoms. These atoms become plasma atoms together with rare gas atoms. HCT are useful and versatile devices and a number of matter-light interaction experiments can be made. In this way several spectroscopy parameters can be determined, like some optical transition absorption cross sections and

excited state lifetime. Atom temperature and density can be measured by optical absorption techniques [1]. Another technique that presents a much higher sensibility than atomic absorption is the optogalvanic spectroscopy [2]. In this work the performance of new geometry HCT was verified concerning its features, mainly related with electric noise. Minimum cathode-anode voltage and low electric noise are desirable features for a given current density HCT operation [3]. These conditions indicate a good cleaning of the internal components and the buffer gas. The gas temperature was measured by two different processes. First, by measuring the Doppler broadening of the  $3p^5 4p(^3S_1) \rightarrow 3p^5 4d(^3D_1^o)$  absorption transition line in the optogalvanic signal (OGS). This transition can be seen with add of Figure 1, where the simplified argon energy levels are shown. Second, by direct measurement of the outer wall cathode temperature and using a heat conduction model to calculate the gas temperature profile. Both results were compared and discussed.

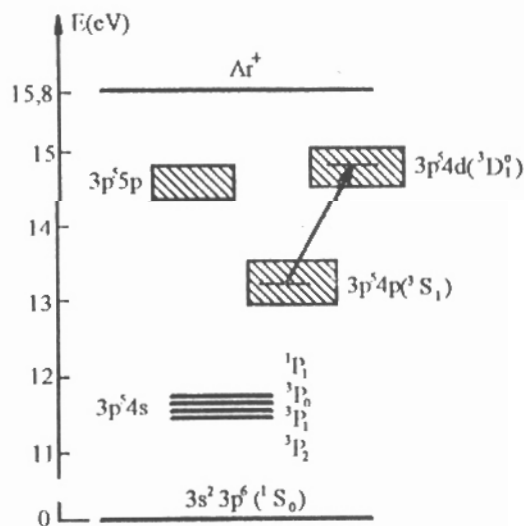

Figure 1 - Simplified argon energy level

## 2. TUBE DESCRIPTION

The tube schematic drawing is shown in Figure 2. The cathode consists of a steel cylinder (0.2% C and 99.8% Fe) with 24 mm length and 8.0 mm radius with a 2.8 mm diameter hole. The cathode was supported by two circular alumina ( $Al_2O_3$ , 99.5%) disks. The cylindrical cathode is centrally attached to the alumina disks. In one of the disks a number of holes were machined in order to allow the insertion of the cathode feed wires. A thermocouple was placed in contact with the cathode surface to measure the

cathode temperature. The tube was made of borasilicate glass type Corning 7740 with dimensions of 40 mm in diameter and 18 cm in length. The windows were made of fused-quartz and arranged in Brewster angle. The tube was baked for many hours, and several electric discharges were applied across the tube in order to produce a heating in the tube internal parts and therefore a degassing. A turbo molecular system (Balzer, mod. THP 240) was used to produce a high vacuum. The tube was sealed with 5 Torr argon pressure (high purity 99,9995%).



Figura 2. Fe-Ar hollow cathode tube.

## 3. EXPERIMENTAL SETUP

In order to measure the optogalvanic signal, the experimental arrangement described below, was employed. An argon laser (Spectra Physics mod. 171) was used to pump the tunable dye laser. The wavelength emitted by the dye laser (Spectra Physics mod. 380 A) was measured using a wavemeter (Burleigh mod. WA-1000). The laser radiation emitted from the dye laser went through the

hollow cathode, inducing the particular transition  $3p^5 4p(^3S_1) \rightarrow 3p^5 4d(^3D_1^o)$  of the argon atoms in the plasma. The interaction was measured as a change in the plasma impedance by a lock-in amplifier. The results were stored in a personal computer. The experimental setup for the optogalvanic measurement is shown in Figure 3.

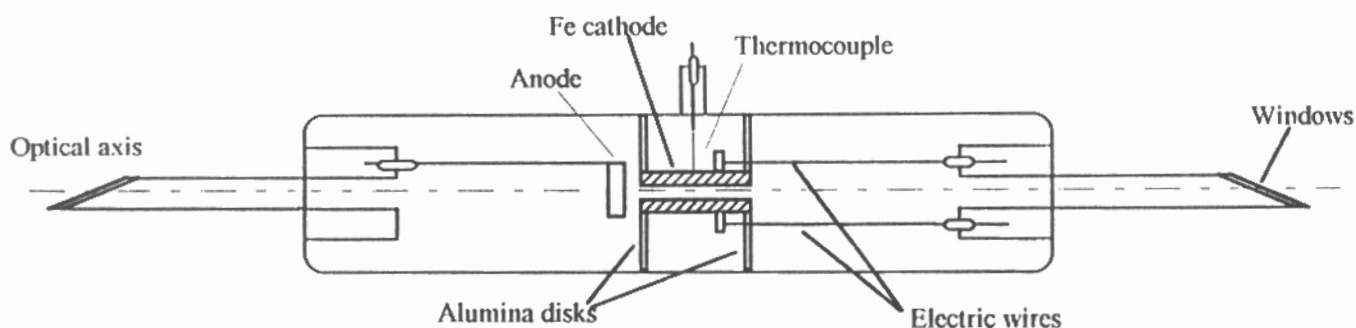
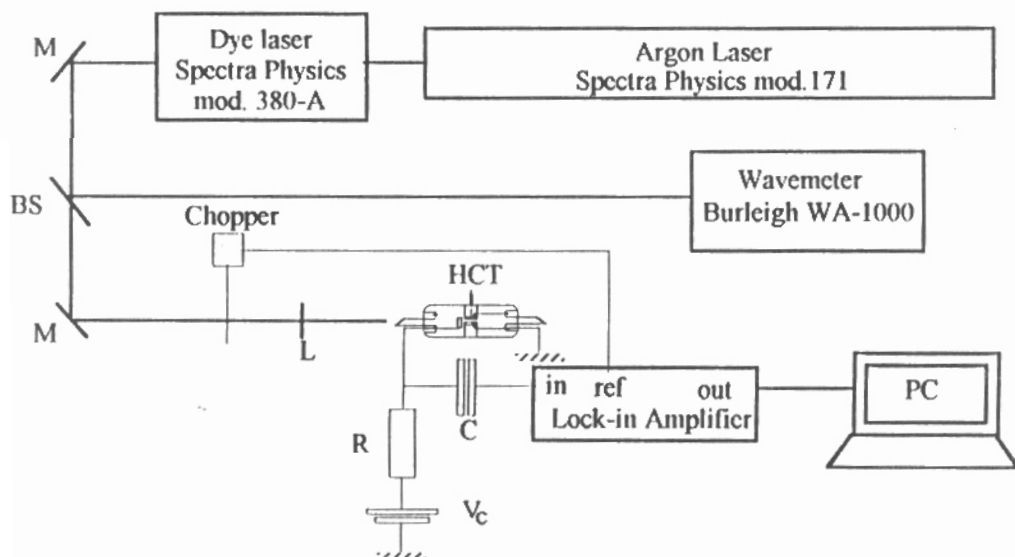

Figure 3. Experimental setup for optogalvanic measurements

#### 4. MODEL FOR TEMPERATURE PROFILE

The theoretical model for determination of the temperature profile assumes the following hypothesis.

- The electric power density supplied by the dc power supply is totally deposited in cathode volume of discharge;
- Thermal conduction is the main mechanism of heat transfer;
- The diameter of cathode hole is small compared to the cathode length. So that one dimension is enough to characterize the system;
- Steady state is assumed. All temperature measurements were made after the system became time independent.

In view of these considerations, the following equations can be written:

For the gas region,  $0 \leq r \leq a$ , where  $a$  is the hole cathode radius, and  $r$ , the radial coordinate, the equation below holds [4],

$$\frac{1}{r} \frac{d}{dr} \left( r k_g(T_g) \frac{dT_g}{dr} \right) = -\dot{q} \quad (1)$$

where, it is assumed that dependence of the gas thermal conductivity  $k_g$  with the gas temperature  $T_g$  is given by

$$k_g(T_g) = AT_g^m$$

where  $A = 1.77 \times 10^{-3} W \cdot m^{-1} K^{-1}$  and  $m = 0.5$  [5].  $\dot{q}$  is the power density supplied by the electric power supply. For the cathode region  $a \leq r \leq b$ , where  $b$  is the cathode outer radius, the following equation is considered

$$\frac{1}{r} \frac{d}{dr} \left( r k_c(T_c) \frac{dT_c}{dr} \right) = 0 \quad (2)$$

where, it is assumed that dependence of the cathode thermal conductivity  $k_c$  with the cathode temperature  $T_c$  is given by

$$k_c(T_c) = k(1 + BT_c)$$

where  $k$ ,  $B$  coefficients were obtained from [6] using a linear interpolation. The following boundary conditions must be satisfied

$$\begin{aligned} T_g &= T_c, \text{ for } r = a, \\ k_g(T_g) \frac{dT_g}{dr} &= k_c(T_c) \frac{dT_c}{dr}, \text{ for } r = a, \\ T_c &= T_b, \text{ for } r = b. \end{aligned}$$

where  $T_b$  is the outer wall cathode temperature, that was measured with a thermocouple. It can be shown that the following expressions are solutions of Equations (1) and (2), respectively:

$$T_g(r) = \left\{ T_a^{m+1} + (m+1) \frac{a^2 \dot{q}}{4A} \left[ 1 - \left( \frac{r}{a} \right)^2 \right] \right\}^{\frac{1}{m+1}} \quad (3)$$

for  $0 \leq r \leq a$  and

$$T_c^2(r) + \frac{2}{B} T_c(r) + \frac{\dot{q} a^2}{Bk_c} \ln \frac{b}{r} - T_b \left[ T_b + \frac{2}{B} \right] = 0 \quad (4)$$

and for  $a \leq r \leq b$ . The inner wall temperature  $T_a$  is determined by solving the Equation (4) for  $r = a$ , i. e.,

$$T_a^2 + \frac{2}{B} T_a + \frac{\dot{q} a^2}{Bk_c} \ln \frac{b}{a} - T_b \left[ T_b + \frac{2}{B} \right] = 0$$

#### 5. RESULTS

The results obtained with the theoretical model are shown in Table 1, together with the experimental results. The experiments were carried out for three different power electric density input. In all measurements the dye laser output power was attenuated in order to excite the HCT with about 1mW in order to avoid power broadening. The beamwaist of laser beam inside of the cathode hole was estimated to be 0.3 mm, so the averaged gas temperature was calculated as:

$$\bar{T}_g = \frac{2}{(bw)^2} \int_0^{bw} T_g(r) r dr \quad (5)$$

where  $T_g(r)$  is given by Equation (3) and  $bw$  is the beamwaist.

**Table 1 - Experimental and theoretical results for the gas temperature.**

meas.	VI(W)	$T_b(^{\circ}C)$	$T_a(^{\circ}C)$	$\bar{T}_g(^{\circ}C)$	$T_g(^{\circ}C)$ $r = 0$
1	2.75	247	250	434	464
2	5.08	334	335	651	690
3	7.56	410	413	848	897

The OGS profile obtained from  $3p^5 4p(^3S_1) \rightarrow 3p^5 4d(^3D_1^{\circ})$  argon transition with 7.56W power electric input is shown in Figure 4. This figure shows a Doppler broadening ( $\Delta\nu_D$ ) of 1.85 GHz for 35mA-216V discharge operation. The wavelength corresponding to this transition is 591,2 nm, that is close to the redish part of the visible light.

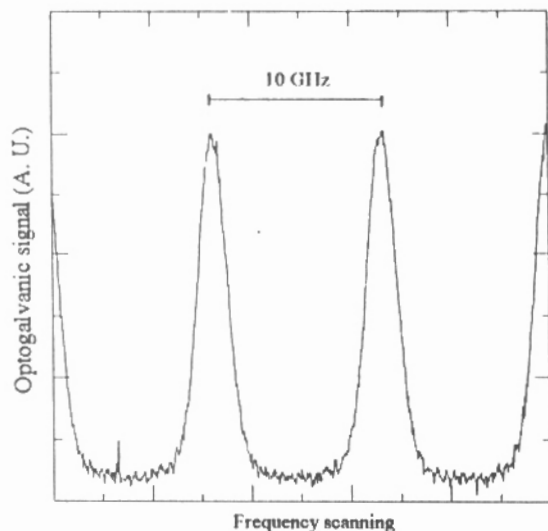

Figure 4 - Doppler limited OGS of the  $3p^5 4p(^3S_1) \rightarrow 3p^5 4d(^3D_0)$  argon transition measured for a 10 GHz laser frequency scanning around the absorption line center (35mA-216V).

The gas temperature can be calculated from the results shown in the Figure 4, assuming that the main broadening line mechanism considered is due to the thermal motion of the atoms. It is assumed that the OGS is proportional to population density difference between the upper and lower transition levels. As  $\Delta V$  is the OGS voltage measured by lock-in amplifier then it can be written that:

$$\Delta V(\nu) \propto \left[ N_u(\nu) - \frac{g_u}{g_l} N_l(\nu) \right]$$

where  $N_u$ ,  $N_l$  are the populations of the upper and lower levels and their  $g_u$ ,  $g_l$  statistic weight, respectively, and  $\nu$  is the frequency around the absorption line center  $\nu_0$ . Then it can be shown [7] that the gas temperature  $T_g$  and the Doppler broadening  $\Delta\nu_D$  are related by

$$T_g = \frac{m_{Ar} (\Delta\nu_D)^2 \lambda^2}{8k_B \ln 2} \quad (6)$$

where  $m_{Ar}$  is the argon mass,  $\lambda$  is the wavelength in the center of transition and the  $k_B$  Boltzmann constant.

Results for three different input electric power are shown in the Table 2 where it is also shown percentual difference between the two methods.

Table 2 - Gas temperature calculated from the broadening line.

meas.	$\Delta\nu_D$ (GHz)	$T_g$ (°C)	% error
1	1.63	536	19
2	1.79	702	7.3
3	1.85	768	9

## 6. CONCLUSIONS

The HCT reported in this work presented a very good performance showing a high signal to noise ratio ( $>20$  dB) as one can see by the Figure 4 analysis. It was possible to compare the gas temperature measurements made by the Doppler broadening of the OGS with those obtained using the theoretical model. So it can be inferred, for the HCT operation used in this work, that the Doppler effect is the main responsible mechanism of line broadening. Therefore, for a given electric power supplied to a HCT, an estimation for gas temperature can be made through the measured value of  $\Delta\nu_D$ . One additional advantage of the tube design described in this work is the utilization of quartz optical windows with Brewster angle, that allows the possibility of using it in some optical intracavity experiments, where polarized laser light is used and low losses of laser intensity are required.

## 7. ACKNOWLEDGEMENTS

The authors wish to thank Mr. Thiago Palmieri for technical support with computer interfaces. This work was supported by Fundação Amparo a Pesquisa do Estado de São Paulo - FAPESP (contract number 95/3660-1).

## 8. REFERENCES

- [1] J. M. Gagné, B. Mongeau, M. Carleer and L. Bertrand. *Appl Opt.* 18, 1084 (1979).
- [2] R. B. Green, R. A. Keller, G. G. Luther, P. K. Schenk and J. C. Travis. *Appl. Phys. Lett.* 29, 727 (1976).
- [3] A. Mirage, D. Pereira, F. C. Cruz and A. Scalabrin. *Il Nuovo Cimento* 14D, n. 6, 605 (1992).
- [4] J. G. Eden and B. E. Cherrington. *J. Appl. Phys.*, 44, 4920 (1973).
- [5] A. B. Campel, "Plasma Physics and Magnetofluidmechanics", McGraw-Hill, NY, 1963.
- [6] Metal Handbook, ed. 9 ed.
- [7] W. Demtröder. "Laser Spectroscopy," Springer Verlag (1981) pg. 86.